



**REQUEST FOR BIDS
SCHEDULE AND INSTRUCTIONS**

**CINCINNATI METROPOLITAN HOUSING AUTHORITY
REQUEST FOR BIDS (RFB) No.
PROJECT MANUAL**

2026 - 9009

**36 Anderson Ferry Rd., Cincinnati, OH 45238 Apt. 1
Modernization**

DATE ISSUED	April 9, 2026
NON-MANDATORY SITE VISIT/WALK THROUGH	April 21, 2026 @ 11:00 am It is suggested that the attendees have read the Scope of Work
LAST DATE FOR QUESTIONS	April 28, 2026 Questions shall be submitted in writing to procurement@cintimha.com . Responses to questions will be posted as an addendum to the website along with the other solicitation documents.
PROPOSAL SUBMITTAL DEADLINE & PUBLIC OPENING	May 7, 2026 @ 11:00 am Sealed Hard Copy Bids must be delivered to: Cincinnati Metropolitan Housing Authority 1627 Western Ave. Cincinnati OH 45214
WHAT TO SUBMIT	Bid Package MUST include the following documents: 1. Bid Form, 2. Bid Bond (If Required), 3. Disclosure of Lobbying Activities, 4. Non-Collusive Affidavit, 5. Form HUD-5369A
NOTICE OF INTENT TO SUBMIT	It is suggested that interested companies submit a Notice of Intent to submit a proposal to procurement@cintimha.com . By indicating your intent to submit a proposal you will receive notice of any addenda posted.
CONSTRUCTION TIME	60 Calendar days from the date stated in the “Notice to Proceed”

CMHA Reserves the right to modify this schedule at its discretion.



REQUEST FOR BIDS CONDITIONS OF THE SOLICITATION

1. In 2012, CMHA established its Gold Performance Standards which consist of the principles and values by which the Agency performs and how our partners, vendors, contractors and consultants are measured.

The Gold Performance Standards are: Respect, Timely, Exceptional, Initiative, Excellent, Quality, Accurate, Integrity, Value, Creativity, Accountability and Professionalism.

It is CMHA's intent to procure Contractors that share these standards and can clearly demonstrate the services they can provide CMHA that no other contractor can offer. It's very imperative that our partners, vendors, contractors and consultants abide by these standards that has been establish.

2. The Contractor shall hold the offer for 90 days after Bid Due Date
3. Notification of changes in the form of Addendums will be made available to all interested parties via an email and/or by posting on CMHA's website.
4. Only the documents stated on the Solicitation as required will be evaluated. DO NOT include additional documents like, but not limited to: references, licenses, curriculum vitae, previous job pictures. Submitting additional documents may cause the proposal to be unresponsive.
5. This project is subject to the requirements of Section 3 of the Housing and Urban Development Act of 1968, as amended. Preference may be given in accordance with 24 CFR 135 and the CMHA procurement policy.
6. The Prevailing Wages shall be paid for a legal day's work to laborers, workmen or mechanics engaged in work under this Contract, at the site of the Project, in the trade or occupation listed.
7. The Authority reserves the right to reject and not consider any proposal that does not meet the requirements of this Solicitation, including but not necessarily limited to incomplete proposals and/or proposals offering alternate or non-requested services, proposals deemed non-responsive, respondents deemed not responsible, and conditional proposals.
8. The responsibility for submitting a response to this request at the designated office of the Cincinnati Metropolitan Housing Authority on or before the stated time and date will be solely and strictly of the Proposer. The Authority will in no way be responsible for the delays caused by the delivery manner chosen by the respondent or caused by any other occurrence.

END OF CONDITIONS



**REQUEST FOR BIDS
INDEX**

SECTION	PAGE
1. <u>Schedule and Instructions</u>	<u>1</u>
2. <u>Conditions of the Solicitation</u>	<u>2</u>
3. <u>Index</u>	<u>3</u>
4. <u>Bid Form <i>Fill, Sign and Return</i></u>	<u>4</u>
5. <u>Non-Collusive Affidavit <i>Fill, Sign and Return.</i></u>	<u>9</u>
6. <u>Disclosure of Lobbying Activities <i>Fill, Sign and Return.</i></u>	<u>10</u>
7. <u>Form HUD-2530 Previous Certificate Participation <i>Fill, Sign and Return.</i></u>	<u>11</u>
8. <u>Form HUD-5369A <i>Fill, Sign and Return</i></u> <u>Representations, Certifications, and other Statements of Bidders, Public and Indian Housing Programs</u>	<u>15</u>
9. <u>Form HUD-5369</u> <u>Instructions to Bidders for Contracts Public & Indian Housing Programs</u>	<u>19</u>
10. <u>CMHA Supplemental Instructions to Bidders (SITB)</u>	<u>24</u>
11. <u>Construction Contract Sample</u>	<u>28</u>
12. <u>Form HUD-5370 General Contract Conditions</u>	<u>31</u>
13. <u>MBE/WBE Participation Report</u>	<u>50</u>
14. <u>Section 3 (S3) Residents and Business Concerns</u>	<u>51</u>
15. <u>Prevailing Wages Clause</u>	<u>55</u>
16. <u>Scope of Work</u>	<u>57</u>
17. <u>Wage Determination Rates</u>	<u>Attachment 1</u>

END OF INDEX



36 Anderson Ferry Rd., Cincinnati, OH 45238 Apt. 1 Modernization

RFB No. 2026 - 9009 PROPOSAL

TO THE CINCINNATI METROPOLITAN HOUSING AUTHORITY (CMHA)

In submitting this proposal, _____ understands that the right is reserved by the Cincinnati Metropolitan Housing Authority to reject any and all Proposals. If written notice of the acceptance of this proposal is mailed, telegraphed or delivered to the undersigned within 90 days after the opening thereof, or at any time thereafter before this proposal is withdrawn, the undersigned agrees to execute and deliver a contract in the prescribed form and furnish the required bond and insurance certifications no later than 10 days after the "Notice of Intent".

1. Total Proposal Amount (TPA)

The base proposal (Valid for 90 days after Proposal Due Date) to include all work indicated, administrative costs and Addendums, is

Figure _____ Dollars.

Words

Note: The Total Proposal Amount shall be shown in both words and figures; in case of discrepancy, the amount in words shall govern. To be valid proposal, the Fee Submission Form must be filled out in its entirety with all certifications and affidavits. It must be submitted with and is part of the Proposal Packet.

Work under this Contract will begin immediately upon the successful Contractor's receipt of a "Notice to Proceed" from CMHA. The "Notice to Proceed" will follow the completion of an executed contract.

2. Acknowledgment's

I acknowledge receipt and acceptance of the following:

- | | |
|---|---|
| <input type="checkbox"/> Scope of Work | <input type="checkbox"/> Wage Determination Rates |
| <input type="checkbox"/> General Contract Conditions HUD-5370 | <input type="checkbox"/> Addendum No. Dated: |
| <input type="checkbox"/> MBE/WBE Participation Report | <input type="checkbox"/> Addendum No. Dated: |
| <input type="checkbox"/> S3 Residents and Business Concerns | <input type="checkbox"/> Addendum No. Dated: |
| <input type="checkbox"/> Prevailing Wages Clause | |

3. Basis of Contract Award

CMHA intends to award this Contract / Purchase Order to the responsible bidder submitting the Lowest "TPA" complying with these Public Bid Specifications, Drawings and Addenda, if any, provided the Contractor's, proposal is reasonable and it is in the best interest of CMHA to accept it.



REQUEST FOR BIDS BID FORM

4. Contract Time

The contract performance period from the “Notice to Proceed” until Substantial Completion, will be **60** Calendar Days.

5. Unit Costs

Unit costs shall be inclusive of materials, labor, overhead and profit. The unit prices offered will be used to increase or decrease the Total Contract Amount based on the existing conditions determined by the Owner at the time of construction of any given building. No unit prices may be used without the written permission of the Owner. CMHA has the right to reject any proposal, which indicates an unbalanced proposal or prices not realistic for the work.

6. Minority Business Enterprise (MBE) & Women Business Enterprise (WBE)

The contractor agrees to make its best effort to expend at least 20% of the total dollar amount of the Contract on Minority Business Enterprises (MBE), an entity with at least 51% ownership interest by a minority in business), and at least 5% of the Contract to a Women Business Enterprises (WBE), an entity with a least 51% ownership interest by a woman in business.

Prior to award of Contract, the Contractor will submit documents in support of its best efforts to achieve the above stated MBE/WBE participation. Best efforts may be established by documenting that the Contractor:

- Has made efforts to identify appropriate MBE/WBE contractors through community contacts or MBE and WBE associations.
- Has contacted CMHA’s Economic Inclusion Coordinator to help identify potential
- MBE/WBE companies appropriate for the project.
- Has contacted and solicited proposals/Proposals from selected MBE/WBE companies.

Contractors agrees to promptly complete and return all required reports confirming MBE/WBE participation, including Proposed, Amended, and Final MBE/WBE Participation Forms. If requested by CMHA, Contractor agrees to submit proof of payment made to each MBE/WBE subcontractor listed on the MBE/WBE Participation Report.

Request for complete or partial waiver of the contractor’s MBE/WBE participation goals must be made in writing, stating all details in the request, the circumstances, and all relevant information. The request must be accompanied by a record of all efforts taken by the Bidder/Bidder to locate MBE/WBEs, solicit MBE/WBEs, seek assistance from CMHA’s Economic Inclusion Coordinator, or seek help from other community/business resources or technical assistance agencies. CMHA will respond in writing to the Waiver Request within five (5) business days upon receipt.

7. Section 3 Certification of Preference

Please note that a contract with Cincinnati Metropolitan Housing Authority is subject to the requirements of Section 3 of the Housing and Urban Development Act of 1968, as amended and to the Section 3 Action Plan submitted with the proposal for this project.



REQUEST FOR BIDS BID FORM

Type of Business (check all that apply)

- Corporation Partnership Sole Proprietorship Joint Venture
 LLC MBE WBE

You self-certify that your business is, documented within the last six months a Section 3 Business Concern based on one of the below eligibility criteria's. (Check the one that qualifies your business):

- Category 1:** 51 percent or more owned and controlled by low- or very low-income persons (based on household income under HUD-income limits)
- Category 2:** 75 percent or more of the business labor hours to perform the business are performed by low-very low-income persons
- Category 3:** 51 percent owned and controlled by current residents of public housing or Section 8-assisted housing.
- My business does not meet the Section 3 eligibility criteria and wishes to forgo Section 3 preferences in the awarding of this contract, but understand that we are still responsible for meeting Section 3 compliance.

8. Section 3 – Action Plan

Please check any and all efforts from the below mentioned categories that your company will utilize to:

- recruit, solicit, encourage, facilitate and hire Section 3 Workers when new hiring/training opportunities are generated through the awarding of the contract.
- recruit, solicit, encourage, facilitate and Subcontract with Section 3 Business Concerns when new subcontracting opportunities are generated through the awarding of the contract.

Your acknowledgment is still needed, so please check accordingly. The Section 3 Action Plan is subject to audit at any time during the awarding of the contract through the duration of the contract by the Section 3 Compliance Coordinator

You are required to the provide opportunities to “the greatest extent feasible” in order to comply with the requirements of Section 3. In the event that you are not able to hire/train and/or contract with Section 3 Residents and/or Section 3 Business Concerns, you will be required to document why you were unable to meet the numerical goals.

a. Opportunities Strategies - Hiring / Training

- **Mandatory** Commit that the company and/or subcontractors as a result of the contract, 25% of the labors hours will be Section 3 Workers.
- **Mandatory** Contact the CMHA Section 3 Compliance Coordinator regarding employment and training opportunities.
- **Mandatory** Provide the CMHA Section 3 Compliance Coordinator with a monthly report listing all employment and training opportunities.
- **Mandatory** Post notice (placards) at the worksite where the work is being done, indicating any employment and training opportunities
- Facilitate or co-facilitate Hiring Halls within close proximity to where the work is being done for Section 3 Workers and Tags.



**REQUEST FOR BIDS
BID FORM**

- Contact/Meet with Resident Associations informing them of new training and employment opportunities.
- Advertise new training and employment opportunities in community and diversity newspapers/websites.
- Sponsor or participate in job informational meetings or job fairs in the neighborhood or service area of the Section 3 covered project.
- Establish an internal training program (pre-apprenticeship) that is consistent with Dept. of Labor requirements to provide Section 3 Workers with the opportunity to learn skills and job requirements.
- Distribute flyers to CMHA owned sites indicating the number and types of jobs that will be offered with contact information.
- Maintain a file of eligible qualified Section 3 Workers and Targeted Section 3 Workers for future employment opportunities.
- Incorporate into contract (after selection of Bidders but prior to the execution of contracts), a negotiated provision for a specific number of Section 3 Workers to be trained and/or employed during the contract.
- Other: _____

b. Opportunities Strategies - Subcontracting

- **Mandatory** Contact the CMHA Section 3 Compliance Coordinator regarding all new subcontracting opportunities.
- **Mandatory** Provide the CMHA Section 3 Compliance Coordinator with a monthly report listing all subcontracting opportunities.
- Advertise new contracting opportunities in community and diversity newspapers/websites.
- Maintain a file of eligible qualified Section 3 Business Concerns for future contracting opportunities.
- Incorporate into contract (after selection of Bidders but prior to the execution of contracts), a negotiated provision for a specific amount of work to be contracted with Section 3 Business Concern(s) during the contract.
- Sponsor or participate in minority, women, small business expositions and or conferences in the Cincinnati, Ohio area to network and promote contracting opportunities with Section 3 Business Concern
- Outreach to business assistance agencies, minority contracting associations, community organizations, to network and promote contracting opportunities with Section 3 Business Concerns.
- Contact/Meet with Resident Associations informing them of new contracting opportunities.
- Outreach to trade/labor organizations to network and promote contracting opportunities with Section 3 Business Concerns.
- Host/Facilitate workshops geared to Section 3 Business concerns on contracting procedures and opportunities.
- Become an active mentor to Section 3 Business Concerns.
- Other: _____



**REQUEST FOR BIDS
BID FORM**

The undersigned is familiar with the local conditions, regulations and codes affecting the cost of the work, and with the Drawings and Specifications, issued and Addenda, if any thereto.

The penalty for making false statements in any offer is prescribed in 19 U.S.C. 1001.

FILL WITH LEGIBLE BLOCK LETTERS

Amount: _____

Legal Business Name: _____

DBA Name (If Applicable): _____

Business Address: _____

City, State, Zip: _____

Fed. Tax ID: _____

Business SAM.gov Unique Entity ID: _____

Email.: _____

Phone. No.: _____

Signature: _____

Name: _____

Title: _____

Direct to Section3@cintimha.com any questions regarding CMHA's:

- MBE/WBE Program
- Section 3 Business Concerns

For CMHA use only – Do not write below the line

Responsiveness Check List

- Bid Form
- Non-Collusive Affidavit
- Disclosure of Lobbying Activities
- Form HUD-2530 Previous Certificate Participation
- Form HUD-5369A

Initials / Date _____



**REQUEST FOR BIDS
NON-COLLUSIVE AFFIDAVIT**

State of _____

County of _____

_____, being first sworn, deposes:

and says that he is _____ of _____
(sole owner, partner, etc.) (Firm Name)

the party making the foregoing proposal or bid, that such proposal or bid is genuine and not collusive or sham; that aspired, connived or agreed, directly or indirectly, with any bidder or person, to put in a sham bid or to refrain from bidding, and has not in any manner, directly, or indirectly, sought by agreement or collusion, or communication or conference, with any person, to fix the bid price of affiant or of any other bidder, or to fix any overhead, profit or cost element of said bid price, to secure any advantage against the Cincinnati Metropolitan Housing Authority or any person interested in the proposed contract; and that all statements in said proposal or bid are true.

Signature of Bidder: _____
(If Individual)

Signature of Bidder: _____
(If Partnership)

Signature of Bidder: _____
(If Corporation)

Subscribed and sworn to before me this ____ day of _____, 20____

_____, My commission expires _____, 20____ Notary Public



**REQUEST FOR BIDS
DISCLOSURE OF LOBBYING ACTIVITIES**

CERTIFICATION

FOR CONTRACTS, GRANTS, LOANS AND COOPERATIVE AGREEMENTS

The undersigned certifies, to the best of his or her knowledge and belief that:

1. No Federal appropriated funds have been paid or will be paid, by or on behalf of the undersigned, to any person for influencing or attempting to influence an officer or employee of an agency, a Member of Congress, an officer or employee of Congress, or an employee of a Member of Congress in connection with the awarding of any Federal contract, the making of any Federal grant, the making of any Federal loan, the entering into of any cooperative agreement, and the extension, continuation, renewal, amendment or modification of any Federal contract, grant, loan, or cooperative agreement.
2. If any funds other than Federal appropriated funds have been paid or will be paid to any person for influencing or attempting to influence an officer or employee of any agency, a Member of Congress, an officer or employee of Congress, or an employee of a Member of Congress in connection with this Federal contract, grant, loan, or cooperative agreement, the undersigned shall complete and submit Standard Form-LLL "Disclosure Form to Report Lobbying," in accordance with its instructions.
3. This certification is a material representation of fact upon which reliance was placed when this transaction was made or entered into. Submission of this certification is a prerequisite for making or entering into this transaction imposed by section 1352, title 31, U.S. Code. Any person who fails to file the required certification shall be subject to a civil penalty of not less than \$10,000 and not more than \$100,000 for each such failure.

Fill with legible block letters

Signature: _____

Name: _____

Title: _____

Date: _____

Covered Action: _____

Type and identify program, project or activity

Previous Participation Certification

OMB Approval No. 2502-0118
(Exp. 05/31/2019)

US Department of Housing and Urban Development
Office of Housing/Federal Housing Commissioner

US Department of Agriculture
Farmers Home Administration

Part I to be completed by Principals of Multifamily Projects (See instructions)		For HUD HQ/FmHA use only	
Reason for submission:			
1. Agency name and City where the application is filed		2. Project Name, Project Number, City and Zip Code	
3. Loan or Contract amount \$		5. Section of Act	
4. Number of Units or Beds		6. Type of Project (check one) <input type="checkbox"/> Existing <input type="checkbox"/> Rehabilitation <input type="checkbox"/> Proposed (New)	

7. List all proposed Principals and attach organization chart for all organizations

Name and address of Principals and Affiliates (Name: Last, First, Middle Initial) proposing to participate	8 Role of Each Principal in Project	9. SSN or IRS Employer Number

Certifications: The principal(s) listed above hereby apply to HUD or USDA FmHA, as the case maybe, for approval to participate as principal(s) in the role(s) and project listed above. The principal(s) each certify that all the statements made on this form are true, complete and correct to the best of their knowledge and belief and are made in good faith, including any Exhibits attached to this form. **Warning:** HUD will prosecute false claims and statements. Conviction may result in criminal and/or civil penalties. The principal(s) further certify that to the best of their knowledge and belief:

- Schedule A contains a listing, for the last ten years, of every project assisted or insured by HUD, USDA FmHA and/or State and local government housing finance agencies in which the principal(s) have participated or are now participating.
- For the period beginning 10 years prior to the date of this certification, and except as shown on the certification:
 - No mortgage on a project listed has ever been in default, assigned to the Government or foreclosed, nor has it received mortgage relief from the mortgagee;
 - The principals have no defaults or noncompliance under any Conventional Contract or Turnkey Contract of Sale in connection with a public housing project;
 - There are no known unresolved findings as a result of HUD audits, management reviews or other Governmental investigations concerning the principals or their projects;
 - There has not been a suspension or termination of payments under any HUD assistance contract due to the principal's fault or negligence;
 - The principals have not been convicted of a felony and are not presently the subject of a complaint or indictment charging a felony. (A felony is defined as any offense punishable by imprisonment for a term exceeding one year, but does not include any offense classified as a misdemeanor under the laws of a State and punishable by imprisonment of two years or less);
 - The principals have not been suspended, debarred or otherwise restricted by any Department or Agency of the Federal Government or of a State Government from doing business with such Department or Agency;
 - The principals have not defaulted on an obligation covered by a surety or performance bond and have not been the subject of a claim under an employee fidelity bond;
 - All the names of the principals who propose to participate in this project are listed above.
- None of the principals is a HUD/FmHA employee or a member of a HUD/FmHA household as defined in Standards of Ethical Conduct for Employees of the Executive Branch in 5 C.F.R. Part 2635 (57 FR 35006) and HUD's Standard of Conduct in 24 C.F.R. Part 0 and USDA's Standard of Conduct in 7 C.F.R. Part 0 Subpart B.
- None of the principals is a participant in an assisted or insured project as of this date on which construction has stopped for a period in excess of 20 days or which has been substantially completed for more than 90 days and documents for closing, including final cost certification, have not been filed with HUD or FmHA.
- None of the principals have been found by HUD or FmHA to be in noncompliance with any applicable fair housing and civil rights requirements in 24 CFR 5.105(a). (If any principals or affiliates have been found to be in noncompliance with any requirements, attach a signed statement explaining the relevant facts, circumstances, and resolution, if any).
- None of the principals is a Member of Congress or a Resident Commissioner nor otherwise prohibited or limited by law from contracting with the Government of the United States of America.
- Statements above (if any) to which the principal(s) cannot certify have been deleted by striking through the words with a pen, and the relevant principal(s) have initialled each deletion (if any) and have attached a true and accurate signed statement (if applicable) to explain the facts and circumstances.

Name of Principal	Signature of Principal	Certification Date(mm/dd/yyyy)	Area Code and Tel. No.
This form prepared by (print name)			Area Code and Tel. No.

Previous editions are obsolete

Page 1 of 2

ref Handbook 4065.1 Form HUD-2530 (2/2013)

Previous Participation Certification

OMB Approval No. 2502-0118
(Exp. 05/31/2019)

Schedule A: List of Previous Projects and Section 8 Contracts. Below is a complete list of the principals' previous participation projects and participation history in multifamily Housing programs of HUD/FmHA, State and local Housing Finance Agencies. **Note:** Read and follow the instruction sheet carefully. Make full disclosure. Add extra sheets if you need more space. Double check for accuracy. If no previous projects, write by your name, **"No previous participation, First Experience"**.

1. Principals Name (Last, First)	2. List of previous projects (Project name, project ID and, Govt. agency involved)	3. List Principals' Role(s) (indicate dates participated, and if fee or identity of interest participant)	4. Status of loan (current, defaulted, assigned, foreclosed)	5. Was the Project ever in default during your participation Yes No If yes, explain	6. Last MOR rating and Physical Insp. Score and date

Part II- For HUD Internal Processing Only

Received and checked by me for accuracy and completeness; recommend approval or refer to Headquarters after checking appropriate box.

Date (mm/dd/yyyy)	Tel No. and area code	<input type="checkbox"/> A. No adverse information; form HUD-2530 approval recommended.	<input type="checkbox"/> C. Disclosure or Certification problem
Staff	Processing and Control	<input type="checkbox"/> B. Name match in system	<input type="checkbox"/> D. Other (attach memorandum)
Supervisor	Director of Housing/Director, Multifamily Division	Approved <input type="checkbox"/> Yes <input type="checkbox"/> No	Date (mm/dd/yyyy)

Previous editions are obsolete

Instructions for Completing the Previous Participation Certificate, form HUD-2530

Carefully read these instructions and the applicable regulations. A copy of those regulations published at 24 C.F.R. 200.210 to 200.245 can be obtained from the Multifamily Housing Representative at any HUD Office. Type or print neatly in ink when filling out this form. Mark answers in all blocks of the form. If the form is not filled completely, it will delay approval of your application.

Attach extra sheets as you need them. Be sure to indicate "Continued on Attachments" wherever appropriate. Sign each additional page that you attach if it refers to you or your record.

Carefully read the certification before you sign it. Any questions regarding the form or how to complete it can be answered by your HUD Office Multifamily Housing Representative.

Purpose: This form provides HUD with a certified report of all previous participation in HUD multifamily housing projects by those parties making application. The information requested in this form is used by HUD to determine if you meet the standards established to ensure that all principal participants in HUD projects will honor their legal, financial and contractual obligations and are acceptable risks from the underwriting standpoint of an insurer, lender or governmental agency. HUD requires that you certify your record of previous participation in HUD/USDA-FmHA, State and Local Housing Finance Agency projects by completing and signing this form, before your project application or participation can be approved.

HUD approval of your certification is a necessary precondition for your participation in the project and in the capacity that you propose. If you do not file this certification, do not furnish the information requested accurately, or do not meet established standards, HUD will not approve your certification.

Note that approval of your certification does not obligate HUD to approve your project application, and it does not satisfy all other HUD program requirements relative to your qualifications.

Who Must Sign and File Form HUD-2530:

Form HUD-2530 must be completed and signed by all principals applying to participate in HUD multifamily housing projects, including those who have no previous participation. The form must be signed and filed by all principals and their affiliates who propose participating in the HUD project. Use a separate form for each role in the project unless there is an identity of interest.

Principals include all individuals, joint ventures,

partnerships, corporations, trusts, non-profit organizations, any other public or private entity that will participate in the proposed project as a sponsor, owner, prime contractor, turnkey developer, managing agent, nursing home administrator or operator, packager, or consultant. Architects and attorneys who have any interest in the project other than an arm's length fee arrangement for professional services are also considered principals by HUD.

In the case of partnerships, all general partners regardless of their percentage interest and limited partners having a 25 percent or more interest in the partnership are considered principals. In the case of public or private corporations or governmental entities, principals include the president, vice president, secretary, treasurer and all other executive officers who are directly responsible to the board of directors, or any equivalent governing body, as well as all directors and each stockholder having a 10 percent or more interest in the corporation.

Affiliates are defined as any person or business concern that directly or indirectly controls the policy of a principal or has the power to do so. A holding or parent corporation would be an example of an affiliate if one of its subsidiaries is a principal.

Exception for Corporations – All principals and affiliates must personally sign the certificate except in the following situation. When a corporation is a principal, all of its officers, directors, trustees and stockholders with 10 percent or more of the common (voting) stock need not sign personally if they all have the same record to report. The officer who is authorized to sign for the corporation or agency will list the names and title of those who elect not to sign. However, any person who has a record of participation in HUD projects that is separate from that of his or her organization must report that activity on this form and sign his or her name. The objective is full disclosure.

Exemptions – The names of the following parties do not need to be listed on form HUD-2530: Public Housing Agencies, tenants, owners of less than five condominium or cooperative units and all others whose interests were acquired by inheritance or court order.

Where and When Form HUD-2530 Must Be Filed:

The original of this form must be submitted to the HUD Office where your project application will be processed at the same time you file your initial project application. This form must be filed with applications for projects, or when otherwise required in the situations listed below:

- Projects to be financed with mortgages insured under the National Housing Act (FHA).
- Projects to be financed according to Section 202 of the Housing Act of 1959 (Elderly and

Handicapped).

- Projects in which 20 percent or more of the units are to receive a subsidy as described in 24 C.F.R. 200.213.

- Purchase of a project subject to a mortgage insured or held by the Secretary of HUD.

- Purchase of a Secretary-owned project.

- Proposed substitution or addition of a principal or principal participation in a different capacity from that previously approved for the same project.

- Proposed acquisition by an existing limited partner of an additional interest in a project resulting in a total interest of 25 percent or more or proposed acquisition by a corporate stockholder of an additional interest in a project resulting in a total interest of 10 percent or more.

- Projects with U.S.D.A., Farmers Home Administration, or with state or local government housing finance agencies that include rental assistance under Section 8 of the Housing Act of 1937. For projects of this type, form HUD-2530 should be filed with the appropriate applications directly to those agencies.

Review of Adverse Determination: If approval of your participation in a HUD project is denied, withheld, or conditionally granted on the basis of your record of previous participation, you will be notified by the HUD Office. You may request reconsideration by the HUD Review Committee. Alternatively, you may request a hearing before a Hearing Officer. Either request must be made in writing within 30 days from your receipt of the notice of determination.

If you do request reconsideration by the Review Committee and the reconsideration results in an adverse determination, you may then request a hearing before a Hearing Officer. The Hearing Officer will issue a report to the Review Committee. You will be notified of the final ruling by certified mail.

Specific Line Instructions:

Reason for submitting this Certification: e.g., refinance, change in ownership, change in management agent, transfer of physical assets, etc.

Block 1: Fill in the name of the agency to which you are applying. For example: HUD Office, Farmers Home Administration District office, or the name of a State or local housing finance agency. Below that, fill in the name of the city where the office is located.

Block 2: Fill in the name of the project, such as "Greenwood Apts." If the name has not yet been selected, write "Name unknown." Below that, enter the HUD contract or project identification number, the Farmers Home Administration project number, or the State or local housing finance agency project or contract number. Include **all** project or contract

identification numbers that are relevant to the project. Also enter the name of the city in which the project is located, and the ZIP Code.

Block 3: Fill in the dollar amount requested in the proposed mortgage, or the annual amount of rental assistance requested.

Block 4: Fill in the number of apartment units proposed, such as "40 units." For hospital projects or nursing homes, fill in the number of beds proposed, such as "100 beds."

Block 5: Fill in the section of the Housing Act under which the application is filed.

Block 7: Definitions of all those who are considered principals and affiliates are given above in the section titled "Who Must Sign and File...."

Block 8: Beside the name of each principal, fill in the appropriate role. The following are examples of possible roles that the principals may assume: Owner/Mortgagor, Managing Agent, Sponsor, Developer, General Contractor, Packager, Consultant, Nursing Home Administrator etc.

Block 9: Fill in the Social Security Number or IRS employer number of every principal listed, including affiliates.

Instructions for Completing Schedule A:

Be sure that Schedule A is filled-in completely, accurately and the certification is properly dated and signed, because it will serve as a legal record of your previous experience. All Multifamily Housing Projects involving HUD/ FmHA, and State and local Housing Finance Agencies in which you have previously participated **must** be listed. Applicants are reminded that previous participation pertains to the individual principal within an entity as well as the entity itself. A newly formed company may not have previous participation, but the principals within the company may have had extensive participation and disclosure of that activity is required.

Column 2. All previous projects must be listed or your certification cannot be processed. Include the name of all projects, project number, city where it is located and the governmental agency (HUD, USDA-FmHA or state or local housing finance agency) that was involved.

Column 3. List the role(s) as a principal, dates participated and if fee or identity of interest (IOI) with owners.

Column 4. Indicate the current status of the loan. Except for current loan, the date associated with the status is required. Loans under a workout arrangement are considered assigned. For all noncurrent loans, an explanation of the status is required.

Column 5. Explain any project defaults during your participation.

Column 6. Provide the latest Management Review (MOR) rating and Physical Inspection score.

Certification: After you have completed all other parts of

a telephone number. By providing a telephone number, HUD can reach you in the event of any questions.

If you cannot certify and sign the certification as it is printed because some statements do not correctly describe your record, use a pen to strike through those parts that differ with your record, and then sign and certify.

Attach a signed statement of explanation of the items you have struck out on the certification. Item 2e. relates to felony convictions within the past 10 years. If you are convicted of

a felony within the past 10 years, strike out 2e. and attach statement of explanation. A felony conviction will not necessarily cause your participation to be disapproved unless there is a criminal record or other evidence that your previous conduct or method of doing business has been such that your participation in the project would make it an unacceptable risk from the underwriting stand point of an insurer, lender or governmental agency.

The Department of Housing and Urban Development (HUD) is authorized to collect this information by law (42 U.S.C. 3535(d) and 24 C.F.R. 200.217) and by regulation at 24 CFR 200.210. This information is needed so that principals applying to participate in multifamily programs can become HUD-approved participants. The information you provide will enable HUD to evaluate your record with respect to established standards of performance, responsibility and eligibility. Without prior approval, a principal may not participate in a proposed or existing multifamily project. HUD uses this information to evaluate whether or not principals pose an unsatisfactory underwriting risk. The information is used to evaluate the potential principals and approve only individuals and organizations that will honor their legal, financial and contractual obligations.

Privacy Act Statement: The Housing and Community Development Act of 1987, 42 U.S.C. 3543 requires persons applying for a Federally-insured or guaranteed loan to furnish his/her Social Security Number (SSN). HUD must have your SSN for identification of your records. HUD may use your SSN for automated processing of your records and to make requests for information about you and your previous records with other public agencies and private sector sources. HUD may disclose certain information to Federal, State and local agencies when relevant to civil, criminal, or regulatory investigations and prosecutions. It will not be otherwise disclosed or released outside of HUD, except as required and permitted by law. You must provide all of the information requested in this application, including your SSN.

Public reporting burden for this collection of information is estimated to average 1 hour per response, including the time for reviewing instructions, searching existing data sources, gathering and maintaining the data needed, and completing and reviewing the collection of information. This agency may not collect this information, and you are not required to complete this form, unless it displays a currently valid OMB control number.

A response is mandatory. Failure to provide any of the information will result in your disapproval of participation in this HUD program.

**U.S. Department of Housing
and Urban Development**
Office of Public and Indian Housing

**Representations, Certifications,
and Other Statements of Bidders**
Public and Indian Housing Programs

Representations, Certifications, and Other Statements of Bidders

Public and Indian Housing Programs

Table of Contents

Clause	Page
1. Certificate of Independent Price Determination	1
2. Contingent Fee Representation and Agreement	1
3. Certification and Disclosure Regarding Payments to Influence Certain Federal Transactions	1
4. Organizational Conflicts of Interest Certification	2
5. Bidder's Certification of Eligibility	2
6. Minimum Bid Acceptance Period	2
7. Small, Minority, Women-Owned Business Concern Representation	2
8. Indian-Owned Economic Enterprise and Indian Organization Representation	2
9. Certification of Eligibility Under the Davis-Bacon Act	3
10. Certification of Nonsegregated Facilities	3
11. Clean Air and Water Certification	3
12. Previous Participation Certificate	3
13. Bidder's Signature	3

1. Certificate of Independent Price Determination

(a) The bidder certifies that--

(1) The prices in this bid have been arrived at independently, without, for the purpose of restricting competition, any consultation, communication, or agreement with any other bidder or competitor relating to (i) those prices, (ii) the intention to submit a bid, or (iii) the methods or factors used to calculate the prices offered;

(2) The prices in this bid have not been and will not be knowingly disclosed by the bidder, directly or indirectly, to any other bidder or competitor before bid opening (in the case of a sealed bid solicitation) or contract award (in the case of a competitive proposal solicitation) unless otherwise required by law; and

(3) No attempt has been made or will be made by the bidder to induce any other concern to submit or not to submit a bid for the purpose of restricting competition.

(b) Each signature on the bid is considered to be a certification by the signatory that the signatory--

(1) Is the person in the bidder's organization responsible for determining the prices being offered in this bid or proposal, and that the signatory has not participated and will not participate in any action contrary to subparagraphs (a)(1) through (a)(3) above; or

(2) (i) Has been authorized, in writing, to act as agent for the following principals in certifying that those principals have not participated, and will not participate in any action contrary to subparagraphs (a)(1) through (a)(3) above.

[insert full name of person(s) in the bidder's organization responsible for determining the prices offered in this bid or proposal, and the title of his or her position in the bidder's organization];

(ii) As an authorized agent, does certify that the principals named in subdivision (b)(2)(i) above have not participated, and will not participate, in any action contrary to subparagraphs (a)(1) through (a)(3) above; and

(iii) As an agent, has not personally participated, and will not participate in any action contrary to subparagraphs (a)(1) through (a)(3) above.

(c) If the bidder deletes or modifies subparagraph (a)2 above, the bidder must furnish with its bid a signed statement setting forth in detail the circumstances of the disclosure.

[X] [Contracting Officer check if following paragraph is applicable]

(d) Non-collusive affidavit. (applicable to contracts for construction and equipment exceeding \$50,000)

(1) Each bidder shall execute, in the form provided by the PHA/IHA, an affidavit to the effect that he/she has not colluded with any other person, firm or corporation in regard to any bid submitted in response to this solicitation. If the successful bidder did not submit the affidavit with his/her bid, he/she must submit it within three (3) working days of bid opening. Failure to submit the affidavit by that date may render the bid nonresponsive. No contract award will be made without a properly executed affidavit.

(2) A fully executed "Non-collusive Affidavit" is, is not included with the bid.

2. Contingent Fee Representation and Agreement

(a) Definitions. As used in this provision:

"Bona fide employee" means a person, employed by a bidder and subject to the bidder's supervision and control as to time, place, and manner of performance, who neither exerts, nor proposes to exert improper influence to solicit or obtain contracts nor holds out as being able to obtain any contract(s) through improper influence.

"Improper influence" means any influence that induces or tends to induce a PHA/IHA employee or officer to give consideration or to act regarding a PHA/IHA contract on any basis other than the merits of the matter.

(b) The bidder represents and certifies as part of its bid that, except for full-time bona fide employees working solely for the bidder, the bidder:

(1) has, has not employed or retained any person or company to solicit or obtain this contract; and

(2) has, has not paid or agreed to pay to any person or company employed or retained to solicit or obtain this contract any commission, percentage, brokerage, or other fee contingent upon or resulting from the award of this contract.

(c) If the answer to either (a)(1) or (a)(2) above is affirmative, the bidder shall make an immediate and full written disclosure to the PHA/IHA Contracting Officer.

(d) Any misrepresentation by the bidder shall give the PHA/IHA the right to (1) terminate the contract; (2) at its discretion, deduct from contract payments the amount of any commission, percentage, brokerage, or other contingent fee; or (3) take other remedy pursuant to the contract.

3. Certification and Disclosure Regarding Payments to Influence Certain Federal Transactions (applicable to contracts exceeding \$100,000)

(a) The definitions and prohibitions contained in Section 1352 of title 31, United States Code, are hereby incorporated by reference in paragraph (b) of this certification.

(b) The bidder, by signing its bid, hereby certifies to the best of his or her knowledge and belief as of December 23, 1989 that:

(1) No Federal appropriated funds have been paid or will be paid to any person for influencing or attempting to influence an officer or employee of any agency, a Member of Congress, an officer or employee of Congress, or an employee of a Member of Congress on his or her behalf in connection with the awarding of a contract resulting from this solicitation;

(2) If any funds other than Federal appropriated funds (including profit or fee received under a covered Federal transaction) have been paid, or will be paid, to any person for influencing or attempting to influence an officer or employee of any agency, a Member of Congress, an officer or employee of Congress, or an employee of a Member of Congress on his or her behalf in connection with this solicitation, the bidder shall complete and submit, with its bid, OMB standard form LLL, "Disclosure of Lobbying Activities;" and

(3) He or she will include the language of this certification in all subcontracts at any tier and require that all recipients of subcontract awards in excess of \$100,000 shall certify and disclose accordingly.

(c) Submission of this certification and disclosure is a prerequisite for making or entering into this contract imposed by section 1352, title 31, United States Code. Any person who makes an expenditure prohibited under this provision or who fails to file or amend the disclosure form to be filed or amended by this provision, shall be subject to a civil penalty of not less than \$10,000, and not more than \$100,000, for each such failure.

(d) Indian tribes (except those chartered by States) and Indian organizations as defined in section 4 of the Indian Self-Determination and Education Assistance Act (25 U.S.C. 450B) are exempt from the requirements of this provision.

4. Organizational Conflicts of Interest Certification

The bidder certifies that to the best of its knowledge and belief and except as otherwise disclosed, he or she does not have any organizational conflict of interest which is defined as a situation in which the nature of work to be performed under this proposed contract and the bidder's organizational, financial, contractual, or other interests may, without some restriction on future activities:

- (a) Result in an unfair competitive advantage to the bidder; or,
- (b) Impair the bidder's objectivity in performing the contract work.

In the absence of any actual or apparent conflict, I hereby certify that to the best of my knowledge and belief, no actual or apparent conflict of interest exists with regard to my possible performance of this procurement.

5. Bidder's Certification of Eligibility

(a) By the submission of this bid, the bidder certifies that to the best of its knowledge and belief, neither it, nor any person or firm which has an interest in the bidder's firm, nor any of the bidder's subcontractors, is ineligible to:

- (1) Be awarded contracts by any agency of the United States Government, HUD, or the State in which this contract is to be performed; or,
- (2) Participate in HUD programs pursuant to 24 CFR Part 24.

(b) The certification in paragraph (a) above is a material representation of fact upon which reliance was placed when making award. If it is later determined that the bidder knowingly rendered an erroneous certification, the contract may be terminated for default, and the bidder may be debarred or suspended from participation in HUD programs and other Federal contract programs.

6. Minimum Bid Acceptance Period

(a) "Acceptance period," as used in this provision, means the number of calendar days available to the PHA/IHA for awarding a contract from the date specified in this solicitation for receipt of bids.

(b) This provision supersedes any language pertaining to the acceptance period that may appear elsewhere in this solicitation.

(c) The PHA/IHA requires a minimum acceptance period of [Contracting Officer insert time period] calendar days.

(d) In the space provided immediately below, bidders may specify a longer acceptance period than the PHA's/IHA's minimum requirement. The bidder allows the following acceptance period: calendar days.

(e) A bid allowing less than the PHA's/IHA's minimum acceptance period will be rejected.

(f) The bidder agrees to execute all that it has undertaken to do, in compliance with its bid, if that bid is accepted in writing within (1) the acceptance period stated in paragraph (c) above or (2) any longer acceptance period stated in paragraph (d) above.

7. Small, Minority, Women-Owned Business Concern Representation

The bidder represents and certifies as part of its bid/ offer that it --

(a) is, is not a small business concern. "Small business concern," as used in this provision, means a concern, including its affiliates, that is independently owned and operated, not dominant in the field of operation in which it is bidding, and qualified as a small business under the criteria and size standards in 13 CFR 121.

(b) is, is not a women-owned business enterprise. "Women-owned business enterprise," as used in this provision, means a business that is at least 51 percent owned by a woman or women who are U.S. citizens and who also control and operate the business.

(c) is, is not a minority business enterprise. "Minority business enterprise," as used in this provision, means a business which is at least 51 percent owned or controlled by one or more minority group members or, in the case of a publicly owned business, at least 51 percent of its voting stock is owned by one or more minority group members, and whose management and daily operations are controlled by one or more such individuals. For the purpose of this definition, minority group members are:

(Check the block applicable to you)

- | | |
|---|---|
| <input type="checkbox"/> Black Americans | <input type="checkbox"/> Asian Pacific Americans |
| <input type="checkbox"/> Hispanic Americans | <input type="checkbox"/> Asian Indian Americans |
| <input type="checkbox"/> Native Americans | <input type="checkbox"/> Hasidic Jewish Americans |

8. Indian-Owned Economic Enterprise and Indian Organization Representation (applicable only if this solicitation is for a contract to be performed on a project for an Indian Housing Authority)

The bidder represents and certifies that it:

(a) is, is not an Indian-owned economic enterprise. "Economic enterprise," as used in this provision, means any commercial, industrial, or business activity established or organized for the purpose of profit, which is at least 51 percent Indian owned. "Indian," as used in this provision, means any person who is a member of any tribe, band, group, pueblo, or community which is recognized by the Federal Government as eligible for services from the Bureau of Indian Affairs and any "Native" as defined in the Alaska Native Claims Settlement Act.

(b) is, is not an Indian organization. "Indian organization," as used in this provision, means the governing body of any Indian tribe or entity established or recognized by such governing body. Indian "tribe" means any Indian tribe, band, group, pueblo, or

community including Native villages and Native groups (including corporations organized by Kenai, Juneau, Sitka, and Kodiak) as defined in the Alaska Native Claims Settlement Act, which is recognized by the Federal Government as eligible for services from the Bureau of Indian Affairs.

9. Certification of Eligibility Under the Davis-Bacon Act (applicable to construction contracts exceeding \$2,000)

(a) By the submission of this bid, the bidder certifies that neither it nor any person or firm who has an interest in the bidder's firm is a person or firm ineligible to be awarded contracts by the United States Government by virtue of section 3(a) of the Davis-Bacon Act or 29 CFR 5.12(a)(1).

(b) No part of the contract resulting from this solicitation shall be subcontracted to any person or firm ineligible to be awarded contracts by the United States Government by virtue of section 3(a) of the Davis-Bacon Act or 29 CFR 5.12(a)(1).

(c) The penalty for making false statements is prescribed in the U. S. Criminal Code, 18 U.S.C. 1001.

10. Certification of Nonsegregated Facilities (applicable to contracts exceeding \$10,000)

(a) The bidder's attention is called to the clause entitled **Equal Employment Opportunity** of the General Conditions of the Contract for Construction.

(b) "Segregated facilities," as used in this provision, means any waiting rooms, work areas, rest rooms and wash rooms, restaurants and other eating areas, time clocks, locker rooms and other storage or dressing areas, parking lots, drinking fountains, recreation or entertainment areas, transportation, and housing facilities provided for employees, that are segregated by explicit directive or are in fact segregated on the basis of race, color, religion, or national origin because of habit, local custom, or otherwise.

(c) By the submission of this bid, the bidder certifies that it does not and will not maintain or provide for its employees any segregated facilities at any of its establishments, and that it does not and will not permit its employees to perform their services at any location under its control where segregated facilities are maintained. The bidder agrees that a breach of this certification is a violation of the Equal Employment Opportunity clause in the contract.

(d) The bidder further agrees that (except where it has obtained identical certifications from proposed subcontractors for specific time periods) prior to entering into subcontracts which exceed \$10,000 and are not exempt from the requirements of the Equal Employment Opportunity clause, it will:

(1) Obtain identical certifications from the proposed subcontractors;

(2) Retain the certifications in its files; and

(3) Forward the following notice to the proposed subcontractors (except if the proposed subcontractors have submitted identical certifications for specific time periods):

Notice to Prospective Subcontractors of Requirement for Certifications of Nonsegregated Facilities

A Certification of Nonsegregated Facilities must be submitted before the award of a subcontract exceeding \$10,000 which is not exempt from the provisions of the Equal Employment Opportunity clause of the prime contract. The certification may be submitted either for each subcontract or for all subcontracts during a period (i.e., quarterly, semiannually, or annually).

Note: The penalty for making false statements in bids is prescribed in 18 U.S.C. 1001.

11. Clean Air and Water Certification (applicable to contracts exceeding \$100,000)

The bidder certifies that:

(a) Any facility to be used in the performance of this contract [] is, [] is not listed on the Environmental Protection Agency List of Violating Facilities:

(b) The bidder will immediately notify the PHA/IHA Contracting Officer, before award, of the receipt of any communication from the Administrator, or a designee, of the Environmental Protection Agency, indicating that any facility that the bidder proposes to use for the performance of the contract is under consideration to be listed on the EPA List of Violating Facilities; and,

(c) The bidder will include a certification substantially the same as this certification, including this paragraph (c), in every nonexempt subcontract.

12. Previous Participation Certificate (applicable to construction and equipment contracts exceeding \$50,000)

(a) The bidder shall complete and submit with his/her bid the Form HUD-2530, "Previous Participation Certificate." If the successful bidder does not submit the certificate with his/her bid, he/she must submit it within three (3) working days of bid opening. Failure to submit the certificate by that date may render the bid nonresponsive. No contract award will be made without a properly executed certificate.

(b) A fully executed "Previous Participation Certificate"

[] is, [] is not included with the bid.

13. Bidder's Signature

The bidder hereby certifies that the information contained in these certifications and representations is accurate, complete, and current.

(Signature and Date)

(Typed or Printed Name)

(Title)

(Company Name)

(Company Address)

**U.S. Department of Housing and
Urban Development**
Office of Public and Indian Housing

**Instructions to Bidders for Contracts
Public and Indian Housing Programs**

Instructions to Bidders for Contracts

Public and Indian Housing Programs

Table of Contents

Clause	Page
1. Bid Preparation and Submission	1
2. Explanations and Interpretations to Prospective Bidders	1
3. Amendments to Invitations for Bids	1
4. Responsibility of Prospective Contractor	1
5. Late Submissions, Modifications, and Withdrawal of Bids	1
6. Bid Opening	2
7. Service of Protest	2
8. Contract Award	2
9. Bid Guarantee	3
10. Assurance of Completion	3
11. Preconstruction Conference	3
12. Indian Preference Requirements	3

1. Bid Preparation and Submission

(a) Bidders are expected to examine the specifications, drawings, all instructions, and, if applicable, the construction site (see also the contract clause entitled **Site Investigation and Conditions Affecting the Work** of the *General Conditions of the Contract for Construction*). Failure to do so will be at the bidders' risk.

(b) All bids must be submitted on the forms provided by the Public Housing Agency/Indian Housing Authority (PHA/IHA). Bidders shall furnish all the information required by the solicitation. Bids must be signed and the bidder's name typed or printed on the bid sheet and each continuation sheet which requires the entry of information by the bidder. Erasures or other changes must be initialed by the person signing the bid. Bids signed by an agent shall be accompanied by evidence of that agent's authority. (Bidders should retain a copy of their bid for their records.)

(c) Bidders must submit as part of their bid a completed form HUD-5369-A, "Representations, Certifications, and Other Statements of Bidders."

(d) All bid documents shall be sealed in an envelope which shall be clearly marked with the words "Bid Documents," the Invitation for Bids (IFB) number, any project or other identifying number, the bidder's name, and the date and time for receipt of bids.

(e) If this solicitation requires bidding on all items, failure to do so will disqualify the bid. If bidding on all items is not required, bidders should insert the words "No Bid" in the space provided for any item on which no price is submitted.

(f) Unless expressly authorized elsewhere in this solicitation, alternate bids will not be considered.

(g) Unless expressly authorized elsewhere in this solicitation, bids submitted by telegraph or facsimile (fax) machines will not be considered.

(h) If the proposed contract is for a Mutual Help project (as described in 24 CFR Part 905, Subpart E) that involves Mutual Help contributions of work, material, or equipment, supplemental information regarding the bid advertisement is provided as an attachment to this solicitation.

2. Explanations and Interpretations to Prospective Bidders

(a) Any prospective bidder desiring an explanation or interpretation of the solicitation, specifications, drawings, etc., must request it at least 7 days before the scheduled time for bid opening. Requests may be oral or written. Oral requests must be confirmed in writing. The only oral clarifications that will be provided will be those clearly related to solicitation procedures, i.e., not substantive technical information. No other oral explanation or interpretation will be provided. Any information given a prospective bidder concerning this solicitation will be furnished promptly to all other prospective bidders as a written amendment to the solicitation, if that information is necessary in submitting bids, or if the lack of it would be prejudicial to other prospective bidders.

(b) Any information obtained by, or provided to, a bidder other than by formal amendment to the solicitation shall not constitute a change to the solicitation.

3. Amendments to Invitations for Bids

(a) If this solicitation is amended, then all terms and conditions which are not modified remain unchanged.

(b) Bidders shall acknowledge receipt of any amendment to this solicitation (1) by signing and returning the amendment, (2) by identifying the amendment number and date on the bid form, or (3) by letter, telegram, or facsimile, if those methods are authorized in the solicitation. The PHA/IHA must receive acknowledgement by the time and at the place specified for receipt of bids. Bids which fail to acknowledge the bidder's receipt of any amendment will result in the rejection of the bid if the amendment(s) contained information which substantively changed the PHA's/IHA's requirements.

(c) Amendments will be on file in the offices of the PHA/IHA and the Architect at least 7 days before bid opening.

4. Responsibility of Prospective Contractor

(a) The PHA/IHA will award contracts only to responsible prospective contractors who have the ability to perform successfully under the terms and conditions of the proposed contract. In determining the responsibility of a bidder, the PHA/IHA will consider such matters as the bidder's:

- (1) Integrity;
- (2) Compliance with public policy;
- (3) Record of past performance; and
- (4) Financial and technical resources (including construction and technical equipment).

(b) Before a bid is considered for award, the bidder may be requested by the PHA/IHA to submit a statement or other documentation regarding any of the items in paragraph (a) above. Failure by the bidder to provide such additional information shall render the bidder nonresponsible and ineligible for award.

5. Late Submissions, Modifications, and Withdrawal of Bids

(a) Any bid received at the place designated in the solicitation after the exact time specified for receipt will not be considered unless it is received before award is made and it:

(1) Was sent by registered or certified mail not later than the fifth calendar day before the date specified for receipt of offers (e.g., an offer submitted in response to a solicitation requiring receipt of offers by the 20th of the month must have been mailed by the 15th);

(2) Was sent by mail, or if authorized by the solicitation, was sent by telegram or via facsimile, and it is determined by the PHA/IHA that the late receipt was due solely to mishandling by the PHA/IHA after receipt at the PHA/IHA; or

(3) Was sent by U.S. Postal Service Express Mail Next Day Service - Post Office to Addressee, not later than 5:00 p.m. at the place of mailing two working days prior to the date specified for receipt of proposals. The term "working days" excludes weekends and observed holidays.

(b) Any modification or withdrawal of a bid is subject to the same conditions as in paragraph (a) of this provision.

(c) The only acceptable evidence to establish the date of mailing of a late bid, modification, or withdrawal sent either by registered or certified mail is the U.S. or Canadian Postal Service postmark both on the envelope or wrapper and on the original receipt from the U.S. or Canadian Postal Service. Both postmarks must show a legible date or the bid, modification, or withdrawal shall be processed as if mailed late. "Postmark" means a printed, stamped, or otherwise placed impression (exclusive of a postage meter machine impression) that is readily identifiable without further action as having been supplied and affixed by employees of the U.S. or Canadian Postal Service on the date of mailing. Therefore, bidders should request the postal clerk to place a hand cancellation bull's-eye postmark on both the receipt and the envelope or wrapper.

(d) The only acceptable evidence to establish the time of receipt at the PHA/IHA is the time/date stamp of PHA/IHA on the proposal wrapper or other documentary evidence of receipt maintained by the PHA/IHA.

(e) The only acceptable evidence to establish the date of mailing of a late bid, modification, or withdrawal sent by Express Mail Next Day Service-Post Office to Addressee is the date entered by the post office receiving clerk on the "Express Mail Next Day Service-Post Office to Addressee" label and the postmark on both the envelope or wrapper and on the original receipt from the U.S. Postal Service. "Postmark" has the same meaning as defined in paragraph (c) of this provision, excluding postmarks of the Canadian Postal Service. Therefore, bidders should request the postal clerk to place a legible hand cancellation bull's eye postmark on both the receipt and Failure by a bidder to acknowledge receipt of the envelope or wrapper.

(f) Notwithstanding paragraph (a) of this provision, a late modification of an otherwise successful bid that makes its terms more favorable to the PHA/IHA will be considered at any time it is received and may be accepted.

(g) Bids may be withdrawn by written notice, or if authorized by this solicitation, by telegram (including mailgram) or facsimile machine transmission received at any time before the exact time set for opening of bids; provided that written confirmation of telegraphic or facsimile withdrawals over the signature of the bidder is mailed and postmarked prior to the specified bid opening time. A bid may be withdrawn in person by a bidder or its authorized representative if, before the exact time set for opening of bids, the identity of the person requesting withdrawal is established and the person signs a receipt for the bid.

6. Bid Opening

All bids received by the date and time of receipt specified in the solicitation will be publicly opened and read. The time and place of opening will be as specified in the solicitation. Bidders and other interested persons may be present.

7. Service of Protest

(a) Definitions. As used in this provision:

"Interested party" means an actual or prospective bidder whose direct economic interest would be affected by the award of the contract.

"Protest" means a written objection by an interested party to this solicitation or to a proposed or actual award of a contract pursuant to this solicitation.

(b) Protests shall be served on the Contracting Officer by obtaining written and dated acknowledgement from —

Procurement Director
Cincinnati Metropolitan Housing Authority
1627 Western Ave.
Cincinnati OH 45214

[Contracting Officer designate the official or location where a protest may be served on the Contracting Officer]

(c) All protests shall be resolved in accordance with the PHA's/IHA's protest policy and procedures, copies of which are maintained at the PHA/IHA.

8. Contract Award

(a) The PHA/IHA will evaluate bids in response to this solicitation without discussions and will award a contract to the responsible bidder whose bid, conforming to the solicitation, will be most advantageous to the PHA/IHA considering only price and any price-related factors specified in the solicitation.

(b) If the apparent low bid received in response to this solicitation exceeds the PHA's/IHA's available funding for the proposed contract work, the PHA/IHA may either accept separately priced items (see 8(e) below) or use the following procedure to determine contract award. The PHA/IHA shall apply in turn to each bid (proceeding in order from the apparent low bid to the high bid) each of the separately priced bid deductible items, if any, in their priority order set forth in this solicitation. If upon the application of the first deductible item to all initial bids, a new low bid is within the PHA's/IHA's available funding, then award shall be made to that bidder. If no bid is within the available funding amount, then the PHA/IHA shall apply the second deductible item. The PHA/IHA shall continue this process until an evaluated low bid, if any, is within the PHA's/IHA's available funding. If upon the application of all deductibles, no bid is within the PHA's/IHA's available funding, or if the solicitation does not request separately priced deductibles, the PHA/IHA shall follow its written policy and procedures in making any award under this solicitation.

(c) In the case of tie low bids, award shall be made in accordance with the PHA's/IHA's written policy and procedures.

(d) The PHA/IHA may reject any and all bids, accept other than the lowest bid (e.g., the apparent low bid is unreasonably low), and waive informalities or minor irregularities in bids received, in accordance with the PHA's/IHA's written policy and procedures.

(e) Unless precluded elsewhere in the solicitation, the PHA/IHA may accept any item or combination of items bid.

(f) The PHA/IHA may reject any bid as nonresponsive if it is materially unbalanced as to the prices for the various items of work to be performed. A bid is materially unbalanced when it is based on prices significantly less than cost for some work and prices which are significantly overstated for other work.

(g) A written award shall be furnished to the successful bidder within the period for acceptance specified in the bid and shall result in a binding contract without further action by either party.

9. Bid Guarantee (applicable to construction and equipment contracts exceeding \$25,000)

All bids must be accompanied by a negotiable bid guarantee which shall not be less than five percent (5%) of the amount of the bid. The bid guarantee may be a certified check, bank draft, U.S. Government Bonds at par value, or a bid bond secured by a surety company acceptable to the U.S. Government and authorized to do business in the state where the work is to be performed. In the case where the work under the contract will be performed on an Indian reservation area, the bid guarantee may also be an irrevocable Letter of Credit (see provision 10, Assurance of Completion, below). Certified checks and bank drafts must be made payable to the order of the PHA/IHA. The bid guarantee shall insure the execution of the contract and the furnishing of a method of assurance of completion by the successful bidder as required by the solicitation. Failure to submit a bid guarantee with the bid shall result in the rejection of the bid. Bid guarantees submitted by unsuccessful bidders will be returned as soon as practicable after bid opening.

10. Assurance of Completion

(a) Unless otherwise provided in State law, the successful bidder shall furnish an assurance of completion prior to the execution of any contract under this solicitation. This assurance may be [Contracting Officer check applicable items] —

[] (1) a performance and payment bond in a penal sum of 100 percent of the contract price; or, as may be required or permitted by State law;

[] (2) separate performance and payment bonds, each for 50 percent or more of the contract price;

[] (3) a 20 percent cash escrow;

[] (4) a 25 percent irrevocable letter of credit; or,

[] (5) an irrevocable letter of credit for 10 percent of the total contract price with a monitoring and disbursements agreement with the IHA (applicable only to contracts awarded by an IHA under the Indian Housing Program).

(b) Bonds must be obtained from guarantee or surety companies acceptable to the U.S. Government and authorized to do business in the state where the work is to be performed. Individual sureties will not be considered. U.S. Treasury Circular Number 570, published annually in the Federal Register, lists companies approved to act as sureties on bonds securing Government contracts, the maximum underwriting limits on each contract bonded, and the States in which the company is licensed to do business. Use of companies listed in this circular is mandatory. Copies of the circular may be downloaded on the U.S. Department of Treasury website <http://www.fms.treas.gov/c570/index.html>, or ordered for a minimum fee by contacting the Government Printing Office at (202) 512-2168.

(c) Each bond shall clearly state the rate of premium and the total amount of premium charged. The current power of attorney for the person who signs for the surety company must be attached to the bond. The effective date of the power of attorney shall not precede the date of the bond. The effective date of the bond shall be on or after the execution date of the contract.

(d) Failure by the successful bidder to obtain the required assurance of completion within the time specified, or within such extended period as the PHA/IHA may grant based upon reasons determined adequate by the PHA/IHA, shall render the bidder ineligible for award. The PHA/IHA may then either award the contract to the next lowest responsible bidder or solicit new bids. The PHA/IHA may retain the ineligible bidder's bid guarantee.

11. Preconstruction Conference (applicable to construction contracts)

After award of a contract under this solicitation and prior to the start of work, the successful bidder will be required to attend a preconstruction conference with representatives of the PHA/IHA and its architect/engineer, and other interested parties convened by the PHA/IHA. The conference will serve to acquaint the participants with the general plan of the construction operation and all other requirements of the contract (e.g., Equal Employment Opportunity, Labor Standards). The PHA/IHA will provide the successful bidder with the date, time, and place of the conference.

12. Indian Preference Requirements (applicable only if this solicitation is for a contract to be performed on a project for an Indian Housing Authority)

(a) HUD has determined that the contract awarded under this solicitation is subject to the requirements of section 7(b) of the Indian Self-Determination and Education Assistance Act (25 U.S.C. 450e(b)). Section 7(b) requires that any contract or subcontract entered into for the benefit of Indians shall require that, to the greatest extent feasible

(1) Preferences and opportunities for training and employment (other than core crew positions; see paragraph (h) below) in connection with the administration of such contracts or subcontracts be given to qualified "Indians." The Act defines "Indians" to mean persons who are members of an Indian tribe and defines "Indian tribe" to mean any Indian tribe, band, nation, or other organized group or community, including any Alaska Native village or regional or village corporation as defined in or established pursuant to the Alaska Native Claims Settlement Act, which is recognized as eligible for the special programs and services provided by the United States to Indians because of their status as Indians; and,

(2) Preference in the award of contracts or subcontracts in connection with the administration of contracts be given to Indian organizations and to Indian-owned economic enterprises, as defined in section 3 of the Indian Financing Act of 1974 (25 U.S.C. 1452). That Act defines "economic enterprise" to mean any Indian-owned commercial, industrial, or business activity established or organized for the purpose of profit, except that the Indian ownership must constitute not less than 51 percent of the enterprise; "Indian organization" to mean the governing body of any Indian tribe or entity established or recognized by such governing body; "Indian" to mean any person who is a member of any tribe, band, group, pueblo, or community which is recognized by the Federal Government as eligible for services from the Bureau of Indian Affairs and any "Native" as defined in the Alaska Native Claims Settlement Act; and Indian "tribe" to mean any Indian tribe, band, group, pueblo, or community including Native villages and Native groups (including

corporations organized by Kenai, Juneau, Sitka, and Kodiak) as defined in the Alaska Native Claims Settlement Act, which is recognized by the Federal Government as eligible for services from the Bureau of Indian Affairs.

(b) (1) The successful Contractor under this solicitation shall comply with the requirements of this provision in awarding all subcontracts under the contract and in providing training and employment opportunities.

(2) A finding by the IHA that the contractor, either (i) awarded a subcontract without using the procedure required by the IHA, (ii) falsely represented that subcontracts would be awarded to Indian enterprises or organizations; or, (iii) failed to comply with the contractor's employment and training preference bid statement shall be grounds for termination of the contract or for the assessment of penalties or other remedies.

(c) If specified elsewhere in this solicitation, the IHA may restrict the solicitation to qualified Indian-owned enterprises and Indian organizations. If two or more (or a greater number as specified elsewhere in the solicitation) qualified Indian-owned enterprises or organizations submit responsive bids, award shall be made to the qualified enterprise or organization with the lowest responsive bid. If fewer than the minimum required number of qualified Indian-owned enterprises or organizations submit responsive bids, the IHA shall reject all bids and readvertise the solicitation in accordance with paragraph (d) below.

(d) If the IHA prefers not to restrict the solicitation as described in paragraph (c) above, or if after having restricted a solicitation an insufficient number of qualified Indian enterprises or organizations submit bids, the IHA may advertise for bids from non-Indian as well as Indian-owned enterprises and Indian organizations. Award shall be made to the qualified Indian enterprise or organization with the lowest responsive bid if that bid is -

(1) Within the maximum HUD-approved budget amount established for the specific project or activity for which bids are being solicited; and

(2) No more than the percentage specified in 24 CFR 905.175(c) higher than the total bid price of the lowest responsive bid from any qualified bidder. If no responsive bid by a qualified Indian-owned economic enterprise or organization is within the stated range of the total bid price of the lowest responsive bid from any qualified enterprise, award shall be made to the bidder with the lowest bid.

(e) Bidders seeking to qualify for preference in contracting or subcontracting shall submit proof of Indian ownership with their bids. Proof of Indian ownership shall include but not be limited to:

(1) Certification by a tribe or other evidence that the bidder is an Indian. The IHA shall accept the certification of a tribe that an individual is a member.

(2) Evidence such as stock ownership, structure, management, control, financing and salary or profit sharing arrangements of the enterprise.

(f) (1) All bidders must submit with their bids a statement describing how they will provide Indian preference in the award of subcontracts. The specific requirements of that statement and the factors to be used by the IHA in determining the statement's adequacy are included as an attachment to this solicitation. Any bid that fails to include the required statement shall be rejected as nonresponsive. The IHA may require that comparable statements be provided by subcontractors to the successful Contractor, and may require the Contractor to reject any bid or proposal by a subcontractor that fails to include the statement.

(2) Bidders and prospective subcontractors shall submit a certification (supported by credible evidence) to the IHA in any instance where the bidder or subcontractor believes it is infeasible to provide Indian preference in subcontracting. The acceptance or rejection by the IHA of the certification shall be final. Rejection shall disqualify the bid from further consideration.

(g) All bidders must submit with their bids a statement detailing their employment and training opportunities and their plans to provide preference to Indians in implementing the contract; and the number or percentage of Indians anticipated to be employed and trained. Comparable statements from all proposed subcontractors must be submitted. The criteria to be used by the IHA in determining the statement(s)'s adequacy are included as an attachment to this solicitation. Any bid that fails to include the required statement(s), or that includes a statement that does not meet minimum standards required by the IHA shall be rejected as nonresponsive.

(h) Core crew employees. A core crew employee is an individual who is a bona fide employee of the contractor at the time the bid is submitted; or an individual who was not employed by the bidder at the time the bid was submitted, but who is regularly employed by the bidder in a supervisory or other key skilled position when work is available. Bidders shall submit with their bids a list of all core crew employees.

(i) Preference in contracting, subcontracting, employment, and training shall apply not only on-site, on the reservation, or within the IHA's jurisdiction, but also to contracts with firms that operate outside these areas (e.g., employment in modular or manufactured housing construction facilities).

(j) Bidders should contact the IHA to determine if any additional local preference requirements are applicable to this solicitation.

(k) The IHA [] does [x] does not [Contracting Officer check applicable box] maintain lists of Indian-owned economic enterprises and Indian organizations by specialty (e.g., plumbing, electrical, foundations), which are available to bidders to assist them in meeting their responsibility to provide preference in connection with the administration of contracts and subcontracts.



REQUEST FOR BIDS SUPPLEMENTAL INSTRUCTIONS TO BIDDERS

These conditions are a supplement to the HUD 5369 Instructions to Bidders and provide information to help clarify articles of that document. Any articles or paragraphs not specifically mentioned shall remain as printed in HUD 5369 without change.

1. Add to Paragraph 1, subparagraph b:
 - i. The bid documents required for the complete bid package shall consist of the following (all shall be signed originals):
 1. Bid Form
 2. Non-Collusive Affidavit
 3. HUD Form 2530
 4. Disclosure of Lobbying Activities
 5. HUD 5369A
2. Add to paragraph 2 subparagraph a
 - a. All questions are to be received in writing. Oral questions will not be accepted. Oral clarifications will not be provided.
 - b. Responses to all written questions will be posted as addendum on the CMHA website at www.cintimha.com.
3. Add to paragraph 4 subparagraph b.1.
 - b.1 Bidders shall indicate receipt of addendum on Bid Form. No other acknowledgement is required.
4. Add to paragraph 4, subparagraph a:
 - a. Ability to demonstrate a minimum of 7 years of experience as a general contractor, performing work of like scope and material, for the period immediately preceding commencement of this CMHA Project for work of the size and type of this CMHA Project.

CMHA, in its sole and absolute discretion, will consider a request for a waiver of the 7 years of experience requirement, if the contractor can establish that it has successfully undertaken and completed such a number of projects of



REQUEST FOR BIDS SUPPLEMENTAL INSTRUCTIONS TO BIDDERS

similar scope and complexity in a lesser number of years so as to confer upon that contractor the same or more experience as other bidders have achieved in 7 or more years of experience.

5. Add to paragraph 5, subparagraph g:

- g. No bid shall be withdrawn for a time period of ninety (90) calendar days from the bid opening. The foregoing limitation upon withdrawal of bids prior to opening shall be subject to the right of withdrawal of a bid made in error as provided by Section 9.31, Ohio Revised Code, to the extent that such statutory provision is applicable.

6. Add to paragraph 10, subparagraphs a, and b:

- a. All bid bonds shall be issued by Surety Companies licensed to issue bonds in the State of Ohio and listed in Federal Register Circular #570. The current power of attorney for the person who signs for any surety company shall be attached to such bid bond.
- b. The CMHA will have the right to retain the bid security of bidders to whom an award is being considered until either (a) the contract has been executed and bonds, if required, have been executed, (b) the specified time has elapsed so that bids may be withdrawn, or (c) all bids have been rejected.

7. Add paragraph 13. Minority Business Enterprise:

It is the goal of CMHA to obtain 20 percent minority business participation on this project.

8. Add paragraph 14. Lead Based Paint:

Any contractor awarded a contract for modernization shall comply with 24 CFR (Code of Federal Regulations) Part 35 prohibiting the use of lead-based paint.

9. Add paragraph 15. Sales Tax Exemption:

The contractor shall take whatever steps required by law to relieve the owner from payment of excise tax and Ohio sales tax on materials, specialties and equipment for contractor to take any part of such action shall constitute the responsibility of the



REQUEST FOR BIDS SUPPLEMENTAL INSTRUCTIONS TO BIDDERS

contractor to make such tax payments as within the scope of this contract. The owner is tax exempt, and upon request will provide a statement to that effect.

10. Add paragraph 16. Liquidated Damages

This project has liquidated damages, as specified in Clause 33 of HUD General Conditions in this contract, which may be charged against contractors who do not complete work on time.

11. Add paragraph 17. Pre-Bid Conference

A pre-bid conference for all prospective contractors will be held as indicated on the Invitation of Bids. Questions will not be received or answered at the pre-bid conference. All questions are to be submitted in writing and responses will be posted as addendum to the CMHA website at www.cintimha.com.

Before presenting a bid, the contractor is advised to have visited the site and be thoroughly familiar with the scope of work and the conditions under which it will be executed. Failure to do so will not release contractor of his obligation to furnish all material and labor necessary to carry out all provisions of the contract.

Add paragraph 18. Definition

Addenda are written or graphic instruments issued by the CMHA prior to the execution of the Contract, which modify or interpret the Bidding Documents by additions, deletions, clarifications or corrections.

A Bid is a complete and properly signed proposal to do the Work for the sums stipulated therein, submitted in accordance with the Bidding Documents.

The Base Bid is the sum stated in the Bid for which the Bidder offers to perform the Work described in the Bidding Documents as the base, to which Work may be in Alternate Bids.

An Alternate Bid or Alternate is an amount stated in the Bid to be added to or deducted from the amount of the Base Bid if the corresponding change in the Work, as described in the Bidding Documents, is accepted. Any alternates accepted by the owner shall be accepted in the order in which they are listed in the form of Bid.



REQUEST FOR BIDS SUPPLEMENTAL INSTRUCTIONS TO BIDDERS

A Unit Price is an amount stated in the Bid as a price per unit of measure for materials, equipment or services or a portion of the Work as described in the Bidding Documents, and to be utilized at CMHA's sole discretion.

12. Add paragraph 19. Form and Style of Bids
 - a. Bids shall be submitted on the form included in the Bidding Documents.
 - b. All blanks on the Bid Form shall be filled in by typewriter or manually in ink.
 - c. Where so indicated by the makeup of the Bid Form, sums shall be expressed in both words and figures, and in case of discrepancy between the two, the amount written in words shall govern.
 - d. The signer of the Bid must initial interlineations, alterations and erasures.
 - e. All requested Alternates shall be bid. If no change in the Base Bid is required, enter "No Change."
 - f. Each copy of the Bid shall include the legal name of the Bidder and a statement that the Bidder is a sole proprietor, partnership, corporation or other legal entity. Each copy shall be signed by the person or persons legally authorized to bind the Bidder to a contract. A Bid by a corporation shall further give the state of incorporation. A Bid submitted by an agent shall have a current power of attorney attached certifying the agent's authority to bind the Bidder.

END OF SECTION



CONSTRUCTION CONTRACT

36 Anderson Ferry Rd., Cincinnati, OH 45238 Apt. 1 **Modernization**

CINCINNATI METROPOLITAN HOUSING AUTHORITY
AND

CONTRACTOR

This Contract is made and entered into between the Cincinnati Metropolitan Housing Authority, hereinafter referred to as “Owner” and the below named, hereinafter referred to as “CONTRACTOR.”

1. PURPOSE AND BACKGROUND

OWNER is the 17th largest public housing authority in the United States. OWNER’s Asset Management Portfolio of properties are owned and operated by OWNER.

The purpose of this contract is for the Contractor to provide construction services at OWNER’s property further described in *The Scope of Work*.

2. STATEMENT OF WORK

The Contractor shall furnish the personnel, material, and/or services and otherwise do all things necessary for or incidental to the performance of the work set forth in *the Scope of Work*

The General Terms and Conditions of the Construction Contract govern the work to be performed under this contract, the nature of the working relationship between OWNER and the Contractor, and specific obligations of both parties.

3. APPLICABLE DOCUMENTS

This contract includes all relevant terms in Solicitation 2024-3035, the Contractor’s Fee Submission Form and all documents, policies, and documents incorporated by reference. All documents, sections, exhibits, clauses, terms and provisions of this Performance Based Contract shall be read so as to be consistent to all extent practicable. In the event that any document, section, clause, exhibit, term or provision of this Contract conflicts with any provision of any of the above-mentioned applicable document, the provision of the instruments listed below shall take precedence in the following order:

- a) Applicable Federal and State of Ohio statutes and regulations
- b) This Instrument (Performance Based Contract)
- c) Solicitation
- d) The Contractor’s Fee
- e) Other Documents incorporated by reference (if applicable)



4. PERIOD OF PERFORMANCE

Subject to other Contract provisions, the period of performance under this Contract shall be from as indicated in the Notice to Proceed, unless sooner terminated or extended as provided herein.

Upon issuance of the Notice to Proceed by Owner, the Contractor shall have two (2) weeks from the issuance of the Notice to submit applications for any required permits. Contractor shall have one (1) week to begin work after receipt of the applicable permits. Failure to meet these deadlines shall constitute a material breach of the terms of this Agreement and shall constitute good cause for the Owner to cancel this contract.

5. COMPENSATION AND PAYMENT

Billing and payment shall be accomplished in accordance with the Contract. OWNER shall pay an amount not to exceed the Fee Amount on item 9 of the *Fee Submission Form*, as breakdown in the Schedule of Values approved by the OWNER, for the performance of all things necessary for, or incidental to the performance of work as set forth in *The Scope of Work*.

Payment shall be contingent upon review and acceptance of the Contractor's Deliverables by OWNER.

OWNER will pay Contractor within 30 days of receipt of properly completed invoices or acceptance of deliverable, whichever is later. Invoices shall be submitted to the Construction Manager or designated not more often than monthly. The invoice shall reference the Contract No., describe and document to OWNER's satisfaction as description of the deliverable accepted by OWNER and the fixed price cost per deliverable. OWNER may, in its sole discretion, withhold payments claimed by Contractor for services rendered if Contractor fails to satisfactorily comply with any term or condition of this Contract. Invoices shall be sent to 1627 Western Ave., Cincinnati, OH 45214

6. WARRANTIES

Contractor warrants that its services and materials provided will be of good quality and consistent with the professional skill and care ordinarily provided by professionals performing the same or similar service and such services and materials shall be provided in accordance with generally accepted industry standards.

At all times Contractor shall comply with all applicable federal, state and local laws, rules, regulations, ordinances and codes and obtain any licenses or permits required to provide the services under this Contract.



2026 - 9009
REQUEST FOR QUOTES
CONSTRUCTION CONTRACT SAMPLE

7. EXECUTIVE REVIEW

This Contract shall be subject to the written approval of OWNER's authorized representative and shall not be binding until so approved.

IN WITNESS WHEREOF, this PROFESSIONAL SERVICES AGREEMENT has been

executed by OWNER and _____
to take effect on _____

Cincinnati Metropolitan Housing Authority
Sign and Date

Contractor
Sign and Date

SAMPLE

General Conditions for Construction Contracts - Public Housing Programs

U.S. Department of Housing and Urban Development
 Office of Public and Indian Housing
 OMB Approval No. 2577-0157 (exp. 11/30/2023)

Applicability. This form is applicable to any construction/development contract greater than \$150,000.

Public reporting burden for this collection of information is estimated to average 1 hour. This includes the time for collecting, reviewing, and reporting the data. The information requested is required to obtain a benefit. This form includes those clauses required by OMB's common rule on grantee procurement, implemented at HUD in 2 CFR 200, and those requirements set forth in Section 3 of the Housing and Urban Development Act of 1968 and its amendment by the Housing and Community Development Act of 1992, implemented by HUD at 24 CFR Part 135. The form is required for construction contracts awarded by Public Housing Agencies (PHAs). The form is used by Housing Authorities in solicitations to provide necessary contract clauses. If the form were not used, PHAs would be unable to enforce their contracts.. There are no assurances of confidentiality. HUD may not conduct or sponsor, and an applicant is not required to respond to a collection of information unless it displays a currently valid OMB control number.

Clause		Page	Clause		Page
1	Definitions	2	Administrative Requirements		
2.	Contractor's Responsibility for Work	2	25.	Contract Period	9
3.	Architect's Duties, Responsibilities and Authority	2	26.	Order of Precedence	9
4.	Other Contracts	3	27.	Payments	9
	Construction Requirements		28.	Contract Modifications	10
5.	Preconstruction Conference and Notice to Proceed	3	29.	Changes	10
6.	Construction Progress Schedule	3	30.	Suspension of Work	11
7.	Site Investigation and Conditions Affecting the Work	3	31.	Disputes	11
8.	Differing Site Conditions	4	32.	Default	11
9.	Specifications and Drawings for Construction	4	33.	Liquidated	12
10.	As-Built Drawings	5	34.	Termination of Convenience	12
11.	Material and Workmanship	5	35.	Assignment of Contract	12
12.	Permits and Codes	5	36.	Insurance	12
13.	Health, Safety, and Accident Prevention	6	37.	Subcontracts	13
14	Temporary Buildings and Transportation Materials	6	38	Subcontracting with Small and Minority Firms, Women's Business Enterprise, and Labor Surplus Area Firms	13
15.	Availability and Use of Utility Services	6	39.	Equal Employment Opportunity	13
16	Protection of Existing Vegetation, Structures, Equipment, Utilities, and Improvements	6	40	Employment, Training, and Contracting Opportunities for Low-Income Persons, Section 3 of the Housing and Urban Development Act of 1968	14
17.	Temporary Buildings and Transportation Materials	7	41.	Interest of Members of Congress	15
18	Clean Air and Water	7	42	Interest of Members, Officers, or Employees and Former Members, Officers, or Employees	15
19.	Energy Efficiency	7	43.	Limitations on Payments Made to Influence	15
20.	Inspection and Acceptance of Construction	7	44.	Royalties and Patents	15
21.	Use and Possession Prior to	8	45.	Examination and Retention of Contractor's Records	15
22.	Warranty of Title	8	46.	Labor Standards-Davis-Bacon and Related Acts	15
23.	Warranty of	8	47.	Non-Federal Prevailing Wage Rates	19
24.	Prohibition Against Liens	9	48.	Procurement of Recovered Materials	19

1. Definitions

- (a) "Architect" means the person or other entity engaged by the PHA to perform architectural, engineering, design, and other services related to the work as provided for in the contract. When a PHA uses an engineer to act in this capacity, the terms "architect" and "engineer" shall be synonymous. The Architect shall serve as a technical representative of the Contracting Officer. The Architect's authority is as set forth elsewhere in this contract.
- (b) "Contract" means the contract entered into between the PHA and the Contractor. It includes the forms of Bid, the Bid Bond, the Performance and Payment Bond or Bonds or other assurance of completion, the Certifications, Representations, and Other Statements of Bidders (form HUD-5370), these General Conditions of the Contract for Construction (form HUD-5370), the applicable wage rate determinations from the U.S. Department of Labor, any special conditions included elsewhere in the contract, the specifications, and drawings. It includes all formal changes to any of those documents by addendum, change order, or other modification.
- (c) "Contracting Officer" means the person delegated the authority by the PHA to enter into, administer, and/or terminate this contract and designated as such in writing to the Contractor. The term includes any successor Contracting Officer and any duly authorized representative of the Contracting Officer also designated in writing. The Contracting Officer shall be deemed the authorized agent of the PHA in all dealings with the Contractor.
- (d) "Contractor" means the person or other entity entering into the contract with the PHA to perform all of the work required under the contract.
- (e) "Drawings" means the drawings enumerated in the schedule of drawings contained in the Specifications and as described in the contract clause entitled Specifications and Drawings for Construction herein.
- (f) "HUD" means the United States of America acting through the Department of Housing and Urban Development including the Secretary, or any other person designated to act on its behalf. HUD has agreed, subject to the provisions of an Annual Contributions Terms and Conditions (ACC), to provide financial assistance to the PHA, which includes assistance in financing the work to be performed under this contract. As defined elsewhere in these General Conditions or the contract documents, the determination of HUD may be required to authorize changes in the work or for release of funds to the PHA for payment to the Contractor. Notwithstanding HUD's role, nothing in this contract shall be construed to create any contractual relationship between the Contractor and HUD.
- (g) "Project" means the entire project, whether construction or rehabilitation, the work for which is provided for in whole or in part under this contract.
- (h) "PHA" means the Public Housing Agency organized under applicable state laws which is a party to this contract.
- (j) "Specifications" means the written description of the technical requirements for construction and includes the criteria and tests for determining whether the requirements are met.
- (l) "Work" means materials, workmanship, and manufacture and fabrication of components.
- (a) The Contractor shall furnish all necessary labor, materials, tools, equipment, and transportation necessary for performance of the work. The Contractor shall also furnish all necessary water, heat, light, and power not made available to the Contractor by the PHA pursuant to the clause entitled Availability and Use of Utility Services herein.
- (b) The Contractor shall perform on the site, and with its own organization, work equivalent to at least [10] (12 percent unless otherwise indicated) of the total amount of work to be performed under the order. This percentage may be reduced by a supplemental agreement to this order if, during performing the work, the Contractor requests a reduction and the Contracting Officer determines that the reduction would be to the advantage of the PHA.
- (c) At all times during performance of this contract and until the work is completed and accepted, the Contractor shall directly superintend the work or assign and have on the work site a competent superintendent who is satisfactory to the Contracting Officer and has authority to act for the Contractor.
- (d) The Contractor shall be responsible for all damages to persons or property that occur as a result of the Contractor's fault or negligence, and shall take proper safety and health precautions to protect the work, the workers, the public, and the property of others. The Contractor shall hold and save the PHA, its officers and agents, free and harmless from liability of any nature occasioned by the Contractor's performance. The Contractor shall also be responsible for all materials delivered and work performed until completion and acceptance of the entire work, except for any completed unit of work which may have been accepted under the contract.
- (e) The Contractor shall lay out the work from base lines and bench marks indicated on the drawings and be responsible for all lines, levels, and measurements of all work executed under the contract. The Contractor shall verify the figures before laying out the work and will be held responsible for any error resulting from its failure to do so.
- (f) The Contractor shall confine all operations (including storage of materials) on PHA premises to areas authorized or approved by the Contracting Officer.
- (g) The Contractor shall at all times keep the work area, including storage areas, free from accumulations of waste materials. After completing the work and before final inspection, the Contractor shall (1) remove from the premises all scaffolding, equipment, tools, and materials (including rejected materials) that are not the property of the PHA and all rubbish caused by its work; (2) leave the work area in a clean, neat, and orderly condition satisfactory to the Contracting Officer; (3) perform all specified tests; and, (4) deliver the installation in complete and operating condition.
- (h) The Contractor's responsibility will terminate when all work has been completed, the final inspection made, and the work accepted by the Contracting Officer. The Contractor will then be released from further obligation except as required by the warranties specified elsewhere in the contract.

3. Architect's Duties, Responsibilities, and Authority

- (a) The Architect for this contract, and any successor, shall be designated in writing by the Contracting Officer.

2. Contractor's Responsibility for Work

- (b) The Architect shall serve as the Contracting Officer's technical representative with respect to architectural, engineering, and design matters related to the work performed under the contract. The Architect may provide direction on contract performance. Such direction shall be within the scope of the contract and may not be of a nature which: (1) institutes additional work outside the scope of the contract; (2) constitutes a change as defined in the Changes clause herein; (3) causes an increase or decrease in the cost of the contract; (4) alters the Construction Progress Schedule; or (5) changes any of the other express terms or conditions of the contract.
- (c) The Architect's duties and responsibilities may include but shall not be limited to:
- (1) Making periodic visits to the work site, and on the basis of his/her on-site inspections, issuing written reports to the PHA which shall include all observed deficiencies. The Architect shall file a copy of the report with the Contractor's designated representative at the site;
 - (2) Making modifications in drawings and technical specifications and assisting the Contracting Officer in the preparation of change orders and other contract modifications for issuance by the Contracting Officer;
 - (3) Reviewing and making recommendations with respect to - (i) the Contractor's construction progress schedules; (ii) the Contractor's shop and detailed drawings; (iii) the machinery, mechanical and other equipment and materials or other articles proposed for use by the Contractor; and, (iv) the Contractor's price breakdown and progress payment estimates; and,
 - (4) Assisting in inspections, signing Certificates of Completion, and making recommendations with respect to acceptance of work completed under the contract.

4. Other Contracts

The PHA may undertake or award other contracts for additional work at or near the site of the work under this contract. The Contractor shall fully cooperate with the other contractors and with PHA employees and shall carefully adapt scheduling and performing the work under this contract to accommodate the additional work, heeding any direction that may be provided by the Contracting Officer. The Contractor shall not commit or permit any act that will interfere with the performance of work by any other contractor or by PHA employees

Construction Requirements

5. Pre-construction Conference and Notice to Proceed

- (a) Within ten calendar days of contract execution, and prior to the commencement of work, the Contractor shall attend a preconstruction conference with representatives of the PHA, its Architect, and other interested parties convened by the PHA. The conference will serve to acquaint the participants with the general plan of the construction operation and all other requirements of the contract. The PHA will provide the Contractor with the date, time, and place of the conference.
- (b) The contractor shall begin work upon receipt of a written Notice to Proceed from the Contracting Officer or designee. The Contractor shall not begin work prior to receiving such notice.

6. Construction Progress Schedule

- (a) The Contractor shall, within five days after the work commences on the contract or another period of time determined by the Contracting Officer, prepare and submit to the Contracting Officer for approval three copies of a practicable schedule showing the order in which the Contractor proposes to perform the work, and the dates on which the Contractor contemplates starting and completing the several salient features of the work (including acquiring labor, materials, and equipment). The schedule shall be in the form of a progress chart of suitable scale to indicate appropriately the percentage of work scheduled for completion by any given date during the period. If the Contractor fails to submit a schedule within the time prescribed, the Contracting Officer may withhold approval of progress payments or take other remedies under the contract until the Contractor submits the required schedule.
- (b) The Contractor shall enter the actual progress on the chart as required by the Contracting Officer, and immediately deliver three copies of the annotated schedule to the Contracting Officer. If the Contracting Officer determines, upon the basis of inspection conducted pursuant to the clause entitled Inspection and Acceptance of Construction, herein that the Contractor is not meeting the approved schedule, the Contractor shall take steps necessary to improve its progress, including those that may be required by the Contracting Officer, without additional cost to the PHA. In this circumstance, the Contracting Officer may require the Contractor to increase the number of shifts, overtime operations, days of work, and/or the amount of construction plant, and to submit for approval any supplementary schedule or schedules in chart form as the Contracting Officer deems necessary to demonstrate how the approved rate of progress will be regained.
- (c) Failure of the Contractor to comply with the requirements of the Contracting Officer under this clause shall be grounds for a determination by the Contracting Officer that the Contractor is not prosecuting the work with sufficient diligence to ensure completion within the time specified in the Contract. Upon making this determination, the Contracting Officer may terminate the Contractor's right to proceed with the work, or any separable part of it, in accordance with the Default clause of this contract.

7. Site Investigation and Conditions Affecting the Work

- (a) The Contractor acknowledges that it has taken steps reasonably necessary to ascertain the nature and location of the work, and that it has investigated and satisfied itself as to the general and local conditions which can affect the work or its cost, including but not limited to, (1) conditions bearing upon transportation, disposal, handling, and storage of materials; (2) the availability of labor, water, electric power, and roads; (3) uncertainties of weather, river stages, tides, or similar physical conditions at the site; (4) the conformation and conditions of the ground; and (5) the character of equipment and facilities needed preliminary to and during work performance. The Contractor also acknowledges that it has satisfied itself as to the character, quality, and quantity of surface and subsurface materials or obstacles to be encountered insofar as this information is

reasonably ascertainable from an inspection of the site, including all exploratory work done by the PHA, as well as from the drawings and specifications made a part of this contract. Any failure of the Contractor to take the actions described and acknowledged in this paragraph will not relieve the Contractor from responsibility for estimating properly the difficulty and cost of successfully performing the work, or for proceeding to successfully perform the work without additional expense to the PHA.

- (b) The PHA assumes no responsibility for any conclusions or interpretations made by the Contractor based on the information made available by the PHA. Nor does the PHA assume responsibility for any understanding reached or representation made concerning conditions which can affect the work by any of its officers or agents before the execution of this contract, unless that understanding or representation is expressly stated in this contract.

8. Differing Site Conditions

- (a) The Contractor shall promptly, and before the conditions are disturbed, give a written notice to the Contracting Officer of (1) subsurface or latent physical conditions at the site which differ materially from those indicated in this contract, or (2) unknown physical conditions at the site(s), of an unusual nature, which differ materially from those ordinarily encountered and generally recognized as inhering in work of the character provided for in the contract.
- (b) The Contracting Officer shall investigate the site conditions promptly after receiving the notice. Work shall not proceed at the affected site, except at the Contractor's risk, until the Contracting Officer has provided written instructions to the Contractor. If the conditions do materially so differ and cause an increase or decrease in the Contractor's cost of, or the time required for, performing any part of the work under this contract, whether or not changed as a result of the conditions, the Contractor shall file a claim in writing to the PHA within ten days after receipt of such instructions and, in any event, before proceeding with the work. An equitable adjustment in the contract price, the delivery schedule, or both shall be made under this clause and the contract modified in writing accordingly.
- (c) No request by the Contractor for an equitable adjustment to the contract under this clause shall be allowed, unless the Contractor has given the written notice required; provided, that the time prescribed in (a) above for giving written notice may be extended by the Contracting Officer.
- (d) No request by the Contractor for an equitable adjustment to the contract for differing site conditions shall be allowed if made after final payment under this contract.

9. Specifications and Drawings for Construction

- (a) The Contractor shall keep on the work site a copy of the drawings and specifications and shall at all times give the Contracting Officer access thereto. Anything mentioned in the specifications and not shown on the drawings, or shown on the drawings and not mentioned in the specifications, shall be of like effect as if shown or mentioned in both. In case of difference between drawings and specifications, the specifications shall govern. In case of discrepancy in the figures, in the drawings, or in the specifications, the matter shall be

promptly submitted to the Contracting Officer, who shall promptly make a determination in writing. Any adjustment by the Contractor without such a determination shall be at its own risk and expense. The Contracting Officer shall furnish from time to time such detailed drawings and other information as considered necessary, unless otherwise provided.

- (b) Wherever in the specifications or upon the drawings the words "directed", "required", "ordered", "designated", "prescribed", or words of like import are used, it shall be understood that the "direction", "requirement", "order", "designation", or "prescription", of the Contracting Officer is intended and similarly the words "approved", "acceptable", "satisfactory", or words of like import shall mean "approved by", or "acceptable to", or "satisfactory to" the Contracting Officer, unless otherwise expressly stated.
- (c) Where "as shown" "as indicated", "as detailed", or words of similar import are used, it shall be understood that the reference is made to the drawings accompanying this contract unless stated otherwise. The word "provided" as used herein shall be understood to mean "provide complete in place" that is "furnished and installed".
- (d) "Shop drawings" means drawings, submitted to the PHA by the Contractor, subcontractor, or any lower tier subcontractor, showing in detail (1) the proposed fabrication and assembly of structural elements and (2) the installation (i.e., form, fit, and attachment details) of materials of equipment. It includes drawings, diagrams, layouts, schematics, descriptive literature, illustrations, schedules, performance and test data, and similar materials furnished by the Contractor to explain in detail specific portions of the work required by the contract. The PHA may duplicate, use, and disclose in any manner and for any purpose shop drawings delivered under this contract.
- (e) If this contract requires shop drawings, the Contractor shall coordinate all such drawings, and review them for accuracy, completeness, and compliance with other contract requirements and shall indicate its approval thereon as evidence of such coordination and review. Shop drawings submitted to the Contracting Officer without evidence of the Contractor's approval may be returned for resubmission. The Contracting Officer will indicate an approval or disapproval of the shop drawings and if not approved as submitted shall indicate the PHA's reasons therefore. Any work done before such approval shall be at the Contractor's risk. Approval by the Contracting Officer shall not relieve the Contractor from responsibility for any errors or omissions in such drawings, nor from responsibility for complying with the requirements of this contract, except with respect to variations described and approved in accordance with (f) below.
- (f) If shop drawings show variations from the contract requirements, the Contractor shall describe such variations in writing, separate from the drawings, at the time of submission. If the Architect approves any such variation and the Contracting Officer concurs, the Contracting Officer shall issue an appropriate modification to the contract, except that, if the variation is minor or does not involve a change in price or in time of performance, a modification need not be issued.
- (g) It shall be the responsibility of the Contractor to make timely requests of the PHA for such large scale and full size drawings, color schemes, and other additional information, not already in his possession, which shall be

required in the planning and production of the work. Such requests may be submitted as the need arises, but each such request shall be filed in ample time to permit appropriate action to be taken by all parties involved so as to avoid delay.

- (h) The Contractor shall submit to the Contracting Officer for approval four copies (unless otherwise indicated) of all shop drawings as called for under the various headings of these specifications. Three sets (unless otherwise indicated) of all shop drawings, will be retained by the PHA and one set will be returned to the Contractor. As required by the Contracting Officer, the Contractor, upon completing the work under this contract, shall furnish a complete set of all shop drawings as finally approved. These drawings shall show all changes and revisions made up to the time the work is completed and accepted.
- (i) This clause shall be included in all subcontracts at any tier. It shall be the responsibility of the Contractor to ensure that all shop drawings prepared by subcontractors are submitted to the Contracting Officer.

10. As-Built Drawings

- (a) "As-built drawings," as used in this clause, means drawings submitted by the Contractor or subcontractor at any tier to show the construction of a particular structure or work as actually completed under the contract. "As-built drawings" shall be synonymous with "Record drawings."
- (b) As required by the Contracting Officer, the Contractor shall provide the Contracting Officer accurate information to be used in the preparation of permanent as-built drawings. For this purpose, the Contractor shall record on one set of contract drawings all changes from the installations originally indicated, and record final locations of underground lines by depth from finish grade and by accurate horizontal offset distances to permanent surface improvements such as buildings, curbs, or edges of walks.
- (c) This clause shall be included in all subcontracts at any tier. It shall be the responsibility of the Contractor to ensure that all as-built drawings prepared by subcontractors are submitted to the Contracting Officer.

11. Material and Workmanship

- (a) All equipment, material, and articles furnished under this contract shall be new and of the most suitable grade for the purpose intended, unless otherwise specifically provided in this contract. References in the contract to equipment, material, articles, or patented processes by trade name, make, or catalog number, shall be regarded as establishing a standard of quality and shall not be construed as limiting competition. The Contractor may, at its option, use any equipment, material, article, or process that, in the judgment of, and as approved by the Contracting Officer, is equal to that named in the specifications, unless otherwise specifically provided in this contract.
- (b) Approval of equipment and materials.
 - (1) The Contractor shall obtain the Contracting Officer's approval of the machinery and mechanical and other equipment to be incorporated into the work. When requesting approval, the Contractor shall furnish to the Contracting Officer the name of the manufacturer, the model number, and other information concerning the performance, capacity, nature, and rating of the

machinery and mechanical and other equipment. When required by this contract or by the Contracting Officer, the Contractor shall also obtain the Contracting Officer's approval of the material or articles which the Contractor contemplates incorporating into the work. When requesting approval, the Contractor shall provide full information concerning the material or articles. Machinery, equipment, material, and articles that do not have the required approval shall be installed or used at the risk of subsequent rejection.

- (2) When required by the specifications or the Contracting Officer, the Contractor shall submit appropriately marked samples (and certificates related to them) for approval at the Contractor's expense, with all shipping charges prepaid. The Contractor shall label, or otherwise properly mark on the container, the material or product represented, its place of origin, the name of the producer, the Contractor's name, and the identification of the construction project for which the material or product is intended to be used.
- (3) Certificates shall be submitted in triplicate, describing each sample submitted for approval and certifying that the material, equipment or accessory complies with contract requirements. The certificates shall include the name and brand of the product, name of manufacturer, and the location where produced.
- (4) Approval of a sample shall not constitute a waiver of the PHA right to demand full compliance with contract requirements. Materials, equipment and accessories may be rejected for cause even though samples have been approved.
- (5) Wherever materials are required to comply with recognized standards or specifications, such specifications shall be accepted as establishing the technical qualities and testing methods, but shall not govern the number of tests required to be made nor modify other contract requirements. The Contracting Officer may require laboratory test reports on items submitted for approval or may approve materials on the basis of data submitted in certificates with samples. Check tests will be made on materials delivered for use only as frequently as the Contracting Officer determines necessary to insure compliance of materials with the specifications. The Contractor will assume all costs of retesting materials which fail to meet contract requirements and/or testing materials offered in substitution for those found deficient.
- (6) After approval, samples will be kept in the Project office until completion of work. They may be built into the work after a substantial quantity of the materials they represent has been built in and accepted.
- (c) Requirements concerning lead-based paint. The Contractor shall comply with the requirements concerning lead-based paint contained in the Lead-Based Paint Poisoning Prevention Act (42 U.S.C. 4821-4846) as implemented by 24 CFR Part 35.

12. Permits and Codes

- (a) The Contractor shall give all notices and comply with all applicable laws, ordinances, codes, rules and regulations. Notwithstanding the requirement of the Contractor to comply with the drawings and specifications in the contract, all work installed shall comply with all applicable codes and regulations as amended by any

waivers. Before installing the work, the Contractor shall examine the drawings and the specifications for compliance with applicable codes and regulations bearing on the work and shall immediately report any discrepancy it may discover to the Contracting Officer. Where the requirements of the drawings and specifications fail to comply with the applicable code or regulation, the Contracting Officer shall modify the contract by change order pursuant to the clause entitled Changes herein to conform to the code or regulation.

- (b) The Contractor shall secure and pay for all permits, fees, and licenses necessary for the proper execution and completion of the work. Where the PHA can arrange for the issuance of all or part of these permits, fees and licenses, without cost to the Contractor, the contract amount shall be reduced accordingly.

13. Health, Safety, and Accident Prevention

- (a) In performing this contract, the Contractor shall:
 - (1) Ensure that no laborer or mechanic shall be required to work in surroundings or under working conditions which are unsanitary, hazardous, or dangerous to his/her health and/or safety as determined under construction safety and health standards promulgated by the Secretary of Labor by regulation;
 - (2) Protect the lives, health, and safety of other persons;
 - (3) Prevent damage to property, materials, supplies, and equipment; and,
 - (4) Avoid work interruptions.
- (b) For these purposes, the Contractor shall:
 - (1) Comply with regulations and standards issued by the Secretary of Labor at 29 CFR Part 1926. Failure to comply may result in imposition of sanctions pursuant to the Contract Work Hours and Safety Standards Act (Public Law 91-54, 83 Stat. 96), 40 U.S.C. 3701 et seq.; and
 - (2) Include the terms of this clause in every subcontract so that such terms will be binding on each subcontractor.
- (c) The Contractor shall maintain an accurate record of exposure data on all accidents incident to work performed under this contract resulting in death, traumatic injury, occupational disease, or damage to property, materials, supplies, or equipment, and shall report this data in the manner prescribed by 29 CFR Part 1904.
- (d) The Contracting Officer shall notify the Contractor of any noncompliance with these requirements and of the corrective action required. This notice, when delivered to the Contractor or the Contractor's representative at the site of the work, shall be deemed sufficient notice of the noncompliance and corrective action required. After receiving the notice, the Contractor shall immediately take corrective action. If the Contractor fails or refuses to take corrective action promptly, the Contracting Officer may issue an order stopping all or part of the work until satisfactory corrective action has been taken. The Contractor shall not base any claim or request for equitable adjustment for additional time or money on any stop order issued under these circumstances.
- (e) The Contractor shall be responsible for its subcontractors' compliance with the provisions of this clause. The Contractor shall take such action with respect to any subcontract as the PHA, the Secretary of Housing and Urban Development, or the Secretary of Labor shall direct as a means of enforcing such provisions.

14. Temporary Heating

The Contractor shall provide and pay for temporary heating, covering, and enclosures necessary to properly protect all work and materials against damage by dampness and cold, to dry out the work, and to facilitate the completion of the work. Any permanent heating equipment used shall be turned over to the PHA in the condition and at the time required by the specifications.

15. Availability and Use of Utility Services

- (a) The PHA shall make all reasonably required amounts of utilities available to the Contractor from existing outlets and supplies, as specified in the contract. Unless otherwise provided in the contract, the amount of each utility service consumed shall be charged to or paid for by the Contractor at prevailing rates charged to the PHA or, where the utility is produced by the PHA, at reasonable rates determined by the Contracting Officer. The Contractor shall carefully conserve any utilities furnished without charge.
- (b) The Contractor, at its expense and in a manner satisfactory to the Contracting Officer, shall install and maintain all necessary temporary connections and distribution lines, and all meters required to measure the amount of each utility used for the purpose of determining charges. Before final acceptance of the work by the PHA, the Contractor shall remove all the temporary connections, distribution lines, meters, and associated paraphernalia.

16. Protection of Existing Vegetation, Structures, Equipment, Utilities, and Improvements

- (a) The Contractor shall preserve and protect all structures, equipment, and vegetation (such as trees, shrubs, and grass) on or adjacent to the work site, which are not to be removed under this contract, and which do not unreasonably interfere with the work required under this contract.
- (b) The Contractor shall only remove trees when specifically authorized to do so, and shall avoid damaging vegetation that will remain in place. If any limbs or branches of trees are broken during performance of this contract, or by the careless operation of equipment, or by workmen, the Contractor shall trim those limbs or branches with a clean cut and paint the cut with a tree-pruning compound as directed by the Contracting Officer.
- (c) The Contractor shall protect from damage all existing improvements and utilities (1) at or near the work site and (2) on adjacent property of a third party, the locations of which are made known to or should be known by the Contractor. Prior to disturbing the ground at the construction site, the Contractor shall ensure that all underground utility lines are clearly marked.
- (d) The Contractor shall shore up, brace, underpin, secure, and protect as necessary all foundations and other parts of existing structures adjacent to, adjoining, and in the vicinity of the site, which may be affected by the excavations or other operations connected with the construction of the project.
- (e) Any equipment temporarily removed as a result of work under this contract shall be protected, cleaned, and replaced in the same condition as at the time of award of this contract.

- (f) New work which connects to existing work shall correspond in all respects with that to which it connects and/or be similar to existing work unless otherwise required by the specifications.
- (g) No structural members shall be altered or in any way weakened without the written authorization of the Contracting Officer, unless such work is clearly specified in the plans or specifications.
- (h) If the removal of the existing work exposes discolored or unfinished surfaces, or work out of alignment, such surfaces shall be refinished, or the material replaced as necessary to make the continuous work uniform and harmonious. This, however, shall not be construed to require the refinishing or reconstruction of dissimilar finishes previously exposed, or finished surfaces in good condition, but in different planes or on different levels when brought together by the removal of intervening work, unless such refinishing or reconstruction is specified in the plans or specifications.
- (i) The Contractor shall give all required notices to any adjoining or adjacent property owner or other party before the commencement of any work.
- (j) The Contractor shall indemnify and save harmless the PHA from any damages on account of settlement or the loss of lateral support of adjoining property, any damages from changes in topography affecting drainage, and from all loss or expense and all damages for which the PHA may become liable in consequence of such injury or damage to adjoining and adjacent structures and their premises.
- (k) The Contractor shall repair any damage to vegetation, structures, equipment, utilities, or improvements, including those that are the property of a third party, resulting from failure to comply with the requirements of this contract or failure to exercise reasonable care in performing the work. If the Contractor fails or refuses to repair the damage promptly, the Contracting Officer may have the necessary work performed and charge the cost to the Contractor.

17. Temporary Buildings and Transportation of Materials

- (a) Temporary buildings (e.g., storage sheds, shops, offices, sanitary facilities) and utilities may be erected by the Contractor only with the approval of the Contracting Officer and shall be built with labor and materials furnished by the Contractor without expense to the PHA. The temporary buildings and utilities shall remain the property of the Contractor and shall be removed by the Contractor at its expense upon completion of the work. With the written consent of the Contracting Officer, the buildings and utilities may be abandoned and need not be removed.
- (b) The Contractor shall, as directed by the Contracting Officer, use only established roadways, or use temporary roadways constructed by the Contractor when and as authorized by the Contracting Officer. When materials are transported in prosecuting the work, vehicles shall not be loaded beyond the loading capacity recommended by the manufacturer of the vehicle or prescribed by any federal, state, or local law or regulation. When it is necessary to cross curbs or sidewalks, the Contractor shall protect them from damage. The Contractor shall repair or pay for the repair of any damaged curbs, sidewalks, or roads.

18. Clean Air and Water

The contractor shall comply with the Clean Air Act, as amended, 42 USC 7401 et seq., the Federal Water Pollution Control Water Act, as amended, 33 U.S.C. 1251 et seq., and standards issued pursuant thereto in the facilities in which this contract is to be performed.

19. Energy Efficiency

The Contractor shall comply with mandatory standards and policies relating to energy efficiency which are contained in the energy conservation plan issued in compliance with the Energy Policy and Conservation Act (Pub.L. 94-163) for the State in which the work under the contract is performed.

20. Inspection and Acceptance of Construction

- (a) Definitions. As used in this clause -
 - (1) "Acceptance" means the act of an authorized representative of the PHA by which the PHA approves and assumes ownership of the work performed under this contract. Acceptance may be partial or complete.
 - (2) "Inspection" means examining and testing the work performed under the contract (including, when appropriate, raw materials, equipment, components, and intermediate assemblies) to determine whether it conforms to contract requirements.
 - (3) "Testing" means that element of inspection that determines the properties or elements, including functional operation of materials, equipment, or their components, by the application of established scientific principles and procedures.
- (b) The Contractor shall maintain an adequate inspection system and perform such inspections as will ensure that the work performed under the contract conforms to contract requirements. All work is subject to PHA inspection and test at all places and at all reasonable times before acceptance to ensure strict compliance with the terms of the contract.
- (c) PHA inspections and tests are for the sole benefit of the PHA and do not: (1) relieve the Contractor of responsibility for providing adequate quality control measures; (2) relieve the Contractor of responsibility for loss or damage of the material before acceptance; (3) constitute or imply acceptance; or, (4) affect the continuing rights of the PHA after acceptance of the completed work under paragraph (j) below.
- (d) The presence or absence of the PHA inspector does not relieve the Contractor from any contract requirement, nor is the inspector authorized to change any term or condition of the specifications without the Contracting Officer's written authorization. All instructions and approvals with respect to the work shall be given to the Contractor by the Contracting Officer.
- (e) The Contractor shall promptly furnish, without additional charge, all facilities, labor, and material reasonably needed for performing such safe and convenient inspections and tests as may be required by the Contracting Officer. The PHA may charge to the Contractor any additional cost of inspection or test when work is not ready at the time specified by the Contractor for inspection or test, or when prior rejection makes reinspection or retest necessary. The PHA shall perform all inspections and tests in a manner that will not unnecessarily delay the work. Special, full size, and performance tests shall be performed as described in the contract.

- (f) The PHA may conduct routine inspections of the construction site on a daily basis.
- (g) The Contractor shall, without charge, replace or correct work found by the PHA not to conform to contract requirements, unless the PHA decides that it is in its interest to accept the work with an appropriate adjustment in contract price. The Contractor shall promptly segregate and remove rejected material from the premises.
- (h) If the Contractor does not promptly replace or correct rejected work, the PHA may (1) by contract or otherwise, replace or correct the work and charge the cost to the Contractor, or (2) terminate for default the Contractor's right to proceed.
- (i) If any work requiring inspection is covered up without approval of the PHA, it must, if requested by the Contracting Officer, be uncovered at the expense of the Contractor. If at any time before final acceptance of the entire work, the PHA considers it necessary or advisable, to examine work already completed by removing or tearing it out, the Contractor, shall on request, promptly furnish all necessary facilities, labor, and material. If such work is found to be defective or nonconforming in any material respect due to the fault of the Contractor or its subcontractors, the Contractor shall defray all the expenses of the examination and of satisfactory reconstruction. If, however, such work is found to meet the requirements of the contract, the Contracting Officer shall make an equitable adjustment to cover the cost of the examination and reconstruction, including, if completion of the work was thereby delayed, an extension of time.
- (j) The Contractor shall notify the Contracting Officer, in writing, as to the date when in its opinion all or a designated portion of the work will be substantially completed and ready for inspection. If the Architect determines that the state of preparedness is as represented, the PHA will promptly arrange for the inspection. Unless otherwise specified in the contract, the PHA shall accept, as soon as practicable after completion and inspection, all work required by the contract or that portion of the work the Contracting Officer determines and designates can be accepted separately. Acceptance shall be final and conclusive except for latent defects, fraud, gross mistakes amounting to fraud, or the PHA's right under any warranty or guarantee.

21. Use and Possession Prior to Completion

- (a) The PHA shall have the right to take possession of or use any completed or partially completed part of the work. Before taking possession of or using any work, the Contracting Officer shall furnish the Contractor a list of items of work remaining to be performed or corrected on those portions of the work that the PHA intends to take possession of or use. However, failure of the Contracting Officer to list any item of work shall not relieve the Contractor of responsibility for complying with the terms of the contract. The PHA's possession or use shall not be deemed an acceptance of any work under the contract.
- (b) While the PHA has such possession or use, the Contractor shall be relieved of the responsibility for (1) the loss of or damage to the work resulting from the PHA's possession or use, notwithstanding the terms of the clause entitled Permits and Codes herein; (2) all maintenance costs on the areas occupied; and, (3) furnishing heat, light, power, and water used in the areas

occupied without proper remuneration therefore. If prior possession or use by the PHA delays the progress of the work or causes additional expense to the Contractor, an equitable adjustment shall be made in the contract price or the time of completion, and the contract shall be modified in writing accordingly.

22. Warranty of Title

The Contractor warrants good title to all materials, supplies, and equipment incorporated in the work and agrees to deliver the premises together with all improvements thereon free from any claims, liens or charges, and agrees further that neither it nor any other person, firm or corporation shall have any right to a lien upon the premises or anything appurtenant thereto.

23. Warranty of Construction

- (a) In addition to any other warranties in this contract, the Contractor warrants, except as provided in paragraph (j) of this clause, that work performed under this contract conforms to the contract requirements and is free of any defect in equipment, material, or workmanship performed by the Contractor or any subcontractor or supplier at any tier. This warranty shall continue for a period of one year (one year unless otherwise indicated) from the date of final acceptance of the work. If the PHA takes possession of any part of the work before final acceptance, this warranty shall continue for a period of (one year unless otherwise indicated) from the date that the PHA takes possession.
- (b) The Contractor shall remedy, at the Contractor's expense, any failure to conform, or any defect. In addition, the Contractor shall remedy, at the Contractor's expense, any damage to PHA-owned or controlled real or personal property when the damage is the result of—
 - (1) The Contractor's failure to conform to contract requirements; or
 - (2) Any defects of equipment, material, workmanship or design furnished by the Contractor.
- (c) The Contractor shall restore any work damaged in fulfilling the terms and conditions of this clause. The Contractor's warranty with respect to work repaired or replaced will run for (one year unless otherwise indicated) from the date of repair or replacement.
- (d) The Contracting Officer shall notify the Contractor, in writing, within a reasonable time after the discovery of any failure, defect or damage.
- (e) If the Contractor fails to remedy any failure, defect, or damage within a reasonable time after receipt of notice, the PHA shall have the right to replace, repair or otherwise remedy the failure, defect, or damage at the Contractor's expense.
- (f) With respect to all warranties, express or implied, from subcontractors, manufacturers, or suppliers for work performed and materials furnished under this contract, the Contractor shall:
 - (1) Obtain all warranties that would be given in normal commercial practice;
 - (2) Require all warranties to be executed in writing, for the benefit of the PHA; and,
 - (3) Enforce all warranties for the benefit of the PHA.
- (g) In the event the Contractor's warranty under paragraph (a) of this clause has expired, the PHA may bring suit at its own expense to enforce a subcontractor's, manufacturer's or supplier's warranty.

- (h) Unless a defect is caused by the negligence of the Contractor or subcontractor or supplier at any tier, the Contractor shall not be liable for the repair of any defect of material or design furnished by the PHA nor for the repair of any damage that results from any defect in PHA furnished material or design.
- (i) Notwithstanding any provisions herein to the contrary, the establishment of the time periods in paragraphs (a) and (c) above relate only to the specific obligation of the Contractor to correct the work, and have no relationship to the time within which its obligation to comply with the contract may be sought to be enforced, nor to the time within which proceedings may be commenced to establish the Contractor's liability with respect to its obligation other than specifically to correct the work.
- (j) This warranty shall not limit the PHA's rights under the Inspection and Acceptance of Construction clause of this contract with respect to latent defects, gross mistakes or fraud.

24. Prohibition Against Liens

The Contractor is prohibited from placing a lien on the PHA's property. This prohibition shall apply to all subcontractors at any tier and all materials suppliers.

Administrative Requirements

25. Contract Period

this contract within _____ calendar days of the effective date of the contract, or within the time schedule established in the notice to proceed issued by the Contracting Officer.

26. Order of Provisions

In the event of a conflict between these General Conditions and the Specifications, the General Conditions shall prevail. In the event of a conflict between the contract and any applicable state or local law or regulation, the state or local law or regulation shall prevail; provided that such state or local law or regulation does not conflict with, or is less restrictive than applicable federal law, regulation, or Executive Order. In the event of such a conflict, applicable federal law, regulation, and Executive Order shall prevail.

27. Payments

- (a) The PHA shall pay the Contractor the price as provided in this contract.
- (b) The PHA shall make progress payments approximately every 30 days as the work proceeds, on estimates of work accomplished which meets the standards of quality established under the contract, as approved by the Contracting Officer. The PHA may, subject to written determination and approval of the Contracting Officer, make more frequent payments to contractors which are qualified small businesses.
- (c) Before the first progress payment under this contract, the Contractor shall furnish, in such detail as requested by the Contracting Officer, a breakdown of the total contract price showing the amount included therein for each principal category of the work, which shall substantiate the payment amount requested in order to provide a

- basis for determining progress payments. The breakdown shall be approved by the Contracting Officer and must be acceptable to HUD. If the contract covers more than one project, the Contractor shall furnish a separate breakdown for each. The values and quantities employed in making up this breakdown are for determining the amount of progress payments and shall not be construed as a basis for additions to or deductions from the contract price. The Contractor shall prorate its overhead and profit over the construction period of the contract.
- (d) The Contractor shall submit, on forms provided by the PHA, periodic estimates showing the value of the work performed during each period based upon the approved

submitted not later than 7 days in advance of the date set for payment and are subject to correction and revision as required. The estimates must be approved by the Contracting Officer with the concurrence of the Architect prior to payment. If the contract covers more than one project, the Contractor shall furnish a separate progress payment estimate for each.

- (e) Along with each request for progress payments and the required estimates, the Contractor shall furnish the following certification, or payment shall not be made: I hereby certify, to the best of my knowledge and belief, that:

- (1) The amounts requested are only for performance in accordance with the specifications, terms, and conditions of the contract;
- (2) Payments to subcontractors and suppliers have been made from previous payments received under the contract, and timely payments will be made from the proceeds of the payment covered by this certification, in accordance with subcontract agreements; and,
- (3) This request for progress payments does not include any amounts which the prime contractor intends to withhold or retain from a subcontractor or supplier in accordance with the terms and conditions of the subcontract.

Name:

Title:

Date:

- (f) Except as otherwise provided in State law, the PHA shall retain ten (10) percent of the amount of progress payments until completion and acceptance of all work under the contract; except, that if upon completion of 50 percent of the work, the Contracting Officer, after consulting with the Architect, determines that the Contractor's performance and progress are satisfactory, the PHA may make the remaining payments in full for the work subsequently completed. If the Contracting Officer subsequently determines that the Contractor's performance and progress are unsatisfactory, the PHA shall reinstate the ten (10) percent (or other percentage as provided in State law) retainage until such time as the Contracting Officer determines that performance and progress are satisfactory.
- (g) The Contracting Officer may authorize material delivered on the site and preparatory work done to be taken into consideration when computing progress payments.

Material delivered to the Contractor at locations other than the site may also be taken into consideration if the Contractor furnishes satisfactory evidence that (1) it has acquired title to such material; (2) the material is properly stored in a bonded warehouse, storage yard, or similar suitable place as may be approved by the Contracting Officer; (3) the material is insured to cover its full value; and (4) the material will be used to perform this contract. Before any progress payment which includes delivered material is made, the Contractor shall furnish such documentation as the Contracting Officer may require to assure the protection of the PHA's interest in such materials. The Contractor shall remain responsible for such stored material notwithstanding the transfer of title to the PHA.

- (h) All material and work covered by progress payments made shall, at the time of payment become the sole property of the PHA, but this shall not be construed as (1) relieving the Contractor from the sole responsibility for all material and work upon which payments have been made or the restoration of any damaged work; or, (2) waiving the right of the PHA to require the fulfillment of all of the terms of the contract. In the event the work of the Contractor has been damaged by other contractors or persons other than employees of the PHA in the course of their employment, the Contractor shall restore such damaged work without cost to the PHA and to seek redress for its damage only from those who directly caused it.
- (i) The PHA shall make the final payment due the Contractor under this contract after (1) completion and final acceptance of all work; and (2) presentation of release of all claims against the PHA arising by virtue of this contract, other than claims, in stated amounts, that the Contractor has specifically excepted from the operation of the release. Each such exception shall embrace no more than one claim, the basis and scope of which shall be clearly defined. The amounts for such excepted claims shall not be included in the request for final payment. A release may also be required of the assignee if the Contractor's claim to amounts payable under this contract has been assigned.
- (j) Prior to making any payment, the Contracting Officer may require the Contractor to furnish receipts or other evidence of payment from all persons performing work and supplying material to the Contractor, if the Contracting Officer determines such evidence is necessary to substantiate claimed costs.
- (k) The PHA shall not; (1) determine or adjust any claims for payment or disputes arising there under between the Contractor and its subcontractors or material suppliers; or, (2) withhold any moneys for the protection of the subcontractors or material suppliers. The failure or refusal of the PHA to withhold moneys from the Contractor shall in nowise impair the obligations of any surety or sureties under any bonds furnished under this contract.

28. Contract Modifications

- (a) Only the Contracting Officer has authority to modify any term or condition of this contract. Any contract modification shall be authorized in writing.
- (b) The Contracting Officer may modify the contract unilaterally (1) pursuant to a specific authorization stated in a contract clause (e.g., Changes); or (2) for administrative matters which do not change the rights or

responsibilities of the parties (e.g., change in the PHA address). All other contract modifications shall be in the form of supplemental agreements signed by the Contractor and the Contracting Officer.

- (c) When a proposed modification requires the approval of HUD prior to its issuance (e.g., a change order that exceeds the PHA's approved threshold), such modification shall not be effective until the required approval is received by the PHA.

29. Changes

- (a) The Contracting Officer may, at any time, without notice to the sureties, by written order designated or indicated to be a change order, make changes in the work within the general scope of the contract including changes:
 - (1) In the specifications (including drawings and designs);
 - (2) In the method or manner of performance of the work;
 - (3) PHA-furnished facilities, equipment, materials, services, or site; or,
 - (4) Directing the acceleration in the performance of the work.
- (b) Any other written order or oral order (which, as used in this paragraph (b), includes direction, instruction, interpretation, or determination) from the Contracting Officer that causes a change shall be treated as a change order under this clause; provided, that the Contractor gives the Contracting Officer written notice stating (1) the date, circumstances and source of the order and (2) that the Contractor regards the order as a change order.
- (c) Except as provided in this clause, no order, statement or conduct of the Contracting Officer shall be treated as a change under this clause or entitle the Contractor to an equitable adjustment.
- (d) If any change under this clause causes an increase or decrease in the Contractor's cost of, or the time required for the performance of any part of the work under this contract, whether or not changed by any such order, the Contracting Officer shall make an equitable adjustment and modify the contract in writing. However, except for a adjustment based on defective specifications, no proposal for any change under paragraph (b) above shall be allowed for any costs incurred more than 20 days (5 days for oral orders) before the Contractor gives written notice as required. In the case of defective specifications for which the PHA is responsible, the equitable adjustment shall include any increased cost reasonably incurred by the Contractor in attempting to comply with the defective specifications.
- (e) The Contractor must assert its right to an adjustment under this clause within 30 days after (1) receipt of a written change order under paragraph (a) of this clause, or (2) the furnishing of a written notice under paragraph (b) of this clause, by submitting a written statement describing the general nature and the amount of the proposal. If the facts justify it, the Contracting Officer may extend the period for submission. The proposal may be included in the notice required under paragraph (b) above. No proposal by the Contractor for an equitable adjustment shall be allowed if asserted after final payment under this contract.
- (f) The Contractor's written proposal for equitable adjustment shall be submitted in the form of a lump sum proposal supported with an itemized breakdown of all increases and decreases in the contract in at least the following details:

- (1) Direct Costs. Materials (list individual items, the quantity and unit cost of each, and the aggregate cost); Transportation and delivery costs associated with materials; Labor breakdowns by hours or unit costs (identified with specific work to be performed); Construction equipment exclusively necessary for the change; Costs of preparation and/ or revision to shop drawings resulting from the change; Worker's Compensation and Public Liability Insurance; Employment taxes under FICA and FUTA; and, Bond Costs when size of change warrants revision.
- (2) Indirect Costs. Indirect costs may include overhead, general and administrative expenses, and fringe benefits not normally treated as direct costs.
- (3) Profit. The amount of profit shall be negotiated and may vary according to the nature, extent, and complexity of the work required by the change. The allowability of the direct and indirect costs shall be determined in accordance with the Contract Cost Principles and Procedures for Commercial Firms in Part 31 of the Federal Acquisition Regulation (48 CFR 1-31), as implemented by HUD Handbook 2210.18, in effect on the date of this contract. The Contractor shall not be allowed a profit on the profit received by any subcontractor. Equitable adjustments for deleted work shall include a credit for profit and may include a credit for indirect costs. On proposals covering both increases and decreases in the amount of the contract, the application of indirect costs and profit shall be on the net-change in direct costs for the Contractor or subcontractor performing the work.
- (g) The Contractor shall include in the proposal its request for time extension (if any), and shall include sufficient information and dates to demonstrate whether and to what extent the change will delay the completion of the contract in its entirety.
- (h) The Contracting Officer shall act on proposals within 30 days after their receipt, or notify the Contractor of the date when such action will be taken.
- (i) Failure to reach an agreement on any proposal shall be a dispute under the clause entitled Disputes herein. Nothing in this clause, however, shall excuse the Contractor from proceeding with the contract as changed.
- (j) Except in an emergency endangering life or property, no change shall be made by the Contractor without a prior order from the Contracting Officer.

30. Suspension of Work

- (a) The Contracting Officer may order the Contractor in writing to suspend, delay, or interrupt all or any part of the work of this contract for the period of time that the Contracting Officer determines appropriate for the convenience of the PHA.
- (b) If the performance of all or any part of the work is, for an unreasonable period of time, suspended, delayed, or interrupted (1) by an act of the Contracting Officer in the administration of this contract, or (2) by the Contracting Officer's failure to act within the time specified (or within a reasonable time if not specified) in this contract an adjustment shall be made for any increase in the cost of performance of the contract (excluding profit) necessarily caused by such unreasonable suspension, delay, or interruption and the contract modified in writing accordingly. However, no adjustment shall be made under this clause for any suspension, delay, or interruption to the extent that performance would have

been so suspended, delayed, or interrupted by any other cause, including the fault or negligence of the Contractor or for which any equitable adjustment is provided for or excluded under any other provision of this contract.

- (c) A claim under this clause shall not be allowed (1) for any costs incurred more than 20 days before the Contractor shall have notified the Contracting Officer in writing of the act or failure to act involved (but this requirement shall not apply as to a claim resulting from a suspension order); and, (2) unless the claim, in an amount stated, is asserted in writing as soon as practicable after the termination of the suspension, delay, or interruption, but not later than the date of final payment under the contract.

31. Disputes

- (a) "Claim," as used in this clause, means a written demand or written assertion by one of the contracting parties seeking, as a matter of right, the payment of money in a sum certain, the adjustment or interpretation of contract terms, or other relief arising under or relating to the contract. A claim arising under the contract, unlike a claim relating to the contract, is a claim that can be resolved under a contract clause that provides for the relief sought by the claimant. A voucher, invoice, or other routine request for payment that is not in dispute when submitted is not a claim. The submission may be converted to a claim by complying with the requirements of this clause, if it is disputed either as to liability or amount or is not acted upon in a reasonable time.
- (b) Except for disputes arising under the clauses entitled Labor Standards - Davis Bacon and Related Acts, herein, all disputes arising under or relating to this contract, including any claims for damages for the alleged breach thereof which are not disposed of by agreement, shall be resolved under this clause.
- (c) All claims by the Contractor shall be made in writing and submitted to the Contracting Officer for a written decision. A claim by the PHA against the Contractor shall be subject to a written decision by the Contracting Officer.
- (d) The Contracting Officer shall, within 60 (unless otherwise indicated) days after receipt of the request, decide the claim or notify the Contractor of the date by which the decision will be made.
- (e) The Contracting Officer's decision shall be final unless the Contractor (1) appeals in writing to a higher level in the PHA in accordance with the PHA's policy and procedures, (2) refers the appeal to an independent mediator or arbitrator, or (3) files suit in a court of competent jurisdiction. Such appeal must be made within (30 unless otherwise indicated) days after receipt of the Contracting Officer's decision.
- (f) The Contractor shall proceed diligently with performance of this contract, pending final resolution of any request for relief, claim, appeal, or action arising under or relating to the contract, and comply with any decision of the Contracting Officer.

32. Default

- (a) If the Contractor refuses or fails to prosecute the work, or any separable part thereof, with the diligence that will insure its completion within the time specified in this contract, or any extension thereof, or fails to complete said work within this time, the Contracting Officer may, by written notice to the Contractor, terminate the right to

proceed with the work (or separable part of the work) that has been delayed. In this event, the PHA may take over the work and complete it, by contract or otherwise, and may take possession of and use any materials, equipment, and plant on the work site necessary for completing the work. The Contractor and its sureties shall be liable for any damage to the PHA resulting from the Contractor's refusal or failure to complete the work within the specified time, whether or not the Contractor's right to proceed with the work is terminated. This liability includes any increased costs incurred by the PHA in completing the work.

- (b) The Contractor's right to proceed shall not be terminated or the Contractor charged with damages under this clause if—
- (1) The delay in completing the work arises from unforeseeable causes beyond the control and without the fault or negligence of the Contractor. Examples of such causes include (i) acts of God, or of the public enemy, (ii) acts of the PHA or other governmental entity in either its sovereign or contractual capacity, (iii) acts of another contractor in the performance of a contract with the PHA, (iv) fires, (v) floods, (vi) epidemics, (vii) quarantine restrictions, (viii) strikes, (ix) freight embargoes, (x) unusually severe weather, or (xi) delays of subcontractors or suppliers at any tier arising from unforeseeable causes beyond the control and without the fault or negligence of both the Contractor and the subcontractors or suppliers; and
 - (2) The Contractor, within days (10 days unless otherwise indicated) from the beginning of such delay (unless extended by the Contracting Officer) notifies the Contracting Officer in writing of the causes of delay. The Contracting Officer shall ascertain the facts and the extent of the delay. If, in the judgment of the Contracting Officer, the findings of fact warrant such action, time for completing the work shall be extended by written modification to the contract. The findings of the Contracting Officer shall be reduced to a written decision which shall be subject to the provisions of the Disputes clause of this contract.
- (c) If, after termination of the Contractor's right to proceed, it is determined that the Contractor was not in default, or that the delay was excusable, the rights and obligations of the parties will be the same as if the termination had been for convenience of the PHA.

33. Liquidated Damages

- (a) If the Contractor fails to complete the work within the time specified in the contract, or any extension, as specified in the clause entitled Default of this contract, the Contractor shall pay to the PHA as liquidated damages, the sum of \$ 200 [Contracting Officer insert amount] for each day of delay. If different completion dates are specified in the contract for separate parts or stages of the work, the amount of liquidated damages shall be assessed on those parts or stages which are delayed. To the extent that the Contractor's delay or nonperformance is excused under another clause in this contract, liquidated damages shall not be due the PHA. The Contractor remains liable for damages caused other than by delay.
- (b) If the PHA terminates the Contractor's right to proceed, the resulting damage will consist of liquidated damages until such reasonable time as may be required for final

completion of the work together with any increased costs occasioned the PHA in completing the work.

- (c) If the PHA does not terminate the Contractor's right to proceed, the resulting damage will consist of liquidated damages until the work is completed or accepted.

34. Termination for Convenience

- (a) The Contracting Officer may terminate this contract in whole, or in part, whenever the Contracting Officer determines that such termination is in the best interest of the PHA. Any such termination shall be effected by delivery to the Contractor of a Notice of Termination specifying the extent to which the performance of the work under the contract is terminated, and the date upon which such termination becomes effective.
- (b) If the performance of the work is terminated, either in whole or in part, the PHA shall be liable to the Contractor for reasonable and proper costs resulting from such termination upon the receipt by the PHA of a properly presented claim setting out in detail: (1) the total cost of the work performed to date of termination less the total amount of contract payments made to the Contractor; (2) the cost (including reasonable profit) of settling and paying claims under subcontracts and material orders for work performed and materials and supplies delivered to the site, payment for which has not been made by the PHA to the Contractor or by the Contractor to the subcontractor or supplier; (3) the cost of preserving and protecting the work already performed until the PHA or assignee takes possession thereof or assumes responsibility therefore; (4) the actual or estimated cost of legal and accounting services reasonably necessary to prepare and present the termination claim to the PHA; and (5) an amount constituting a reasonable profit on the value of the work performed by the Contractor.
- (c) The Contracting Officer will act on the Contractor's claim within days (60 days unless otherwise indicated) of receipt of the Contractor's claim.
- (d) Any disputes with regard to this clause are expressly made subject to the provisions of the Disputes clause of this contract.

35. Assignment of Contract

The Contractor shall not assign or transfer any interest in this contract; except that claims for monies due or to become due from the PHA under the contract may be assigned to a bank, trust company, or other financial institution. Such assignments of claims shall only be made with the written concurrence of the Contracting Officer. If the Contractor is a partnership, this contract shall inure to the benefit of the surviving or remaining member(s) of such partnership as approved by the Contracting Officer.

36. Insurance

- (a) Before commencing work, the Contractor and each subcontractor shall furnish the PHA with certificates of insurance showing the following insurance is in force and will insure all operations under the Contract:
- (1) Workers' Compensation, in accordance with state or Territorial Workers' Compensation laws.
 - (2) Commercial General Liability with a combined single limit for bodily injury and property damage of not less than \$ 1,000,000 [Contracting Officer insert amount]

per occurrence to protect the Contractor and each subcontractor against claims for bodily injury or death and damage to the property of others. This shall cover the use of all equipment, hoists, and vehicles on the site(s) not covered by Automobile Liability under (3) below. If the Contractor has a "claims made" policy, then the following additional requirements apply: the policy must provide a "retroactive date" which must be on or before the execution date of the Contract; and the extended reporting period may not be less than five years following the completion date of the Contract.

- (3) Automobile Liability on owned and non-owned motor vehicles used on the site(s) or in connection therewith for a combined single limit for bodily injury and property damage of not less than \$ 1,000,000 [Contracting Officer insert amount] per occurrence.
- (b) Before commencing work, the Contractor shall furnish the PHA with a certificate of insurance evidencing that Builder's Risk (fire and extended coverage) Insurance on all work in place and/or materials stored at the building site(s), including foundations and building equipment, is in force. The Builder's Risk Insurance shall be for the benefit of the Contractor and the PHA as their interests may appear and each shall be named in the policy or policies as an insured. The Contractor in installing equipment supplied by the PHA shall carry insurance on such equipment from the time the Contractor takes possession thereof until the Contract work is accepted by the PHA. The Builder's Risk Insurance need not be carried on excavations, piers, footings, or foundations until such time as work on the superstructure is started. It need not be carried on landscape work. Policies shall furnish coverage at all times for the full cash value of all completed construction, as well as materials in place and/or stored at the site(s), whether or not partial payment has been made by the PHA. The Contractor may terminate this insurance on buildings as of the date taken over for occupancy by the PHA. The Contractor is not required to carry Builder's Risk Insurance for modernization work which does not involve structural alterations or additions and where the PHA's existing fire and extended coverage policy can be endorsed to include such work.
- (c) All insurance shall be carried with companies which are financially responsible and admitted to do business in the State in which the project is located. If any such insurance is due to expire during the construction period, the Contractor (including subcontractors, as applicable) shall not permit the coverage to lapse and shall furnish evidence of coverage to the Contracting Officer. All certificates of insurance, as evidence of coverage, shall provide that no coverage may be canceled or non-renewed by the insurance company until at least 30 days prior written notice has been given to the Contracting Officer.

37. Subcontracts

- (a) Definitions. As used in this contract -
- (1) "Subcontract" means any contract, purchase order, or other purchase agreement, including modifications and change orders to the foregoing, entered into by a subcontractor to furnish supplies, materials, equipment, and services for the performance of the prime contract or a subcontract.

(2) "Subcontractor" means any supplier, vendor, or firm that furnishes supplies, materials, equipment, or services to or for the Contractor or another subcontractor.

- (b) The Contractor shall not enter into any subcontract with any subcontractor who has been temporarily denied participation in a HUD program or who has been suspended or debarred from participating in contracting programs by any agency of the United States Government or of the state in which the work under this contract is to be performed.
- (c) The Contractor shall be as fully responsible for the acts or omissions of its subcontractors, and of persons either directly or indirectly employed by them as for the acts or omissions of persons directly employed by the Contractor.
- (d) The Contractor shall insert appropriate clauses in all subcontracts to bind subcontractors to the terms and conditions of this contract insofar as they are applicable to the work of subcontractors.
- (e) Nothing contained in this contract shall create any contractual relationship between any subcontractor and the PHA or between the subcontractor and HUD.

38. Subcontracting with Small and Minority Firms, Women's Business Enterprise, and Labor Surplus Area Firms

The Contractor shall take the following steps to ensure that, whenever possible, subcontracts are awarded to small business firms, minority firms, women's business enterprises, and labor surplus area firms:

- (a) Placing qualified small and minority businesses and women's business enterprises on solicitation lists;
- (b) Ensuring that small and minority businesses and women's business enterprises are solicited whenever they are potential sources;
- (c) Dividing total requirements, when economically feasible, into smaller tasks or quantities to permit maximum participation by small and minority businesses and women's business enterprises;
- (d) Establishing delivery schedules, where the requirements of the contract permit, which encourage participation by small and minority businesses and women's business enterprises; and
- (e) Using the services and assistance of the U.S. Small Business Administration, the Minority Business Development Agency of the U.S. Department of Commerce, and State and local governmental small business agencies.

39. Equal Employment Opportunity

During the performance of this contract, the Contractor. Rdkdq agrees as follows:

- (a) The Contractor. Rdkdq shall not discriminate against any employee or applicant for employment because of of race,, color, religion, sex, sexual orientation, gender identity, disability, or national origin.
- (b) The Contractor. Rdkdq shall take affirmative action to ensure that applicants are employed, and that employees are treated during employment without regard to their race, color, religion, sex, sexual orientation, gender identity, disability, or national origin. Such action shall include, but not be limited to, (1) employment, (2) upgrading, (3), (3) demotion, (4) transfer, (5) recruitment or recruitment advertising, (6) layoff or termination, (7) rates of pay or other forms of compensation, and (8) selection for training including apprenticeship

(c) The Contractor shall agree to post in conspicuous places available to employees and applicants for employment the notices to be provided by the Contracting Officer setting forth the provisions of this nondiscrimination clause.

(d) The Contractor shall, in all solicitations or advertisements for employees placed by or on behalf of the Contractor/Seller, state that all qualified applicants will receive consideration for employment without regard to race, color, religion, sex, or national origin.

(e) The Contractor shall send, to each labor union or representative of workers with which it has a collective bargaining agreement or other contract or understanding, the notice to be provided by the Contracting Officer advising the labor union or workers' representative of the Contractor's commitments under this clause, and post copies of the notice in conspicuous places available to employees and applicants for employment.

(f) The Contractor shall comply with Executive Order 11246, as amended, and the rules, regulations, and orders of the Secretary of Labor.

(g) The Contractor shall furnish all information and reports required by Executive Order 11246, as amended, Section 503 of the Rehabilitation Act of 1973, as amended, and by rules, regulations, and orders of the Secretary of Labor, or pursuant thereto. The Contractor shall permit access to its books, records, and accounts by the Secretary of Labor for purposes of investigation to ascertain compliance with such rules, regulations, and orders.

(h) In the event of a that the Contractor is in non-compliance with the nondiscrimination clauses of this contract or with any of such rules, regulations, or orders, this contract may be canceled, terminated or suspended in whole or in part and the contractor/seller may be declared ineligible for further Government contracts in accordance with procedures authorized in Executive Order 11246 of September 24, 1965, and such other sanctions may be imposed and remedies invoked as provided in Executive Order 11246 of September 24, 1965, or by rule, regulation, or order of the Secretary of Labor, or as otherwise provided by law.

(i) The contractor/seller will include the provisions of paragraphs (a) through (h) in every subcontract or purchase order unless exempted by rules, regulations, or orders of the Secretary of Labor issued pursuant to section 204 of Executive Order 11246 of September 24, 1965, so that such provisions will be binding upon each sub[contractor/seller] or vendor. The [contractor/seller] will take such action with respect to any subcontract or purchase order as may be directed by the Secretary of Labor as a means of enforcing such provisions including sanctions for noncompliance: Provided, however, that in the event the [contractor/seller] becomes involved in, or is threatened with, litigation with a subcontractor or vendor as a result of such direction, the [contractor/seller] may request the United States to enter into such litigation to protect the interests of the United States.

(j) Compliance with the requirements of this clause shall be to the maximum extent consistent with, but not in derogation of, compliance with section 7(b) of the Indian Self-Determination and Education Assistance Act and the Indian Preference clause of this contract.

40. Employment, Training, and Contracting Opportunities for Low-Income Persons, Section 3 of the Housing and Urban Development Act of 1968.

(a) The work to be performed under this contract is subject to the requirements of section 3 of the Housing and Urban Development Act of 1968, as amended, 12 U.S.C. 1701u (section 3). The purpose of section 3 is to ensure that employment and other economic opportunities generated by HUD assistance or HUD-assisted projects covered by section 3, shall, to the greatest extent feasible, be directed to low- and very low-income persons, particularly persons who are recipients of HUD assistance for housing.

(b) The parties to this contract agree to comply with HUD's regulations in 24 CFR Part 135, which implement section 3. As evidenced by their execution of this contract, the parties to this contract certify that they are under no contractual or other impediment that would prevent them from complying with the Part 135 regulations.

(c) The contractor agrees to send to each labor organization or representative of workers with which the contractor has a collective bargaining agreement or other understanding, if any, a notice advising the labor organization or workers' representative of the contractor's commitments under this section 3 clause, and will post copies of the notice in conspicuous places at the work site where both employees and applicants for training and employment positions can see the notice. The notice shall describe the section 3 preference, shall set forth minimum number and job titles subject to hire, availability of apprenticeship and training positions, the qualifications for each; and the name and location of the person(s) taking applications for each of the positions; and the anticipated date the work shall begin.

(d) The contractor agrees to include this section 3 clause in every subcontract subject to compliance with regulations in 24 CFR Part 135, and agrees to take appropriate action, as provided in an applicable provision of the subcontract or in this section 3 clause, upon a finding that the subcontractor is in violation of the regulations in 24 CFR Part 135. The contractor will not subcontract with any subcontractor where the contractor has notice or knowledge that the subcontractor has been found in violation of the regulations in 24 CFR Part 135.

(e) The contractor will certify that any vacant employment positions, including training positions, that are filled (1) after the contractor is selected but before the contract is executed, and (2) with persons other than those to whom the regulations of 24 CFR Part 135 require employment opportunities to be directed, were not filled to circumvent the contractor's obligations under 24 CFR Part 135.

(f) Noncompliance with HUD's regulations in 24 CFR Part 135 may result in sanctions, termination of this contract for default, and debarment or suspension from future HUD assisted contracts.

(g) With respect to work performed in connection with section 3 covered Indian housing assistance, section 7(b) of the Indian Self-Determination and Education Assistance Act (25 U.S.C. 450e) also applies to the work to be performed under this contract. Section 7(b) requires that to the greatest extent feasible (i) preference and opportunities for training and employment shall be given to Indians, and (ii) preference in the award of contracts and subcontracts shall be given to Indian organizations and Indian-owned Economic Enterprises. Parties to this contract that are subject to the provisions of section 3 and section 7(b) agree to comply with section 3 to the maximum extent feasible, but not in derogation of compliance with section 7(b).

41. Interest of Members of Congress

No member of or delegate to the Congress of the United States of America shall be admitted to any share or part of this contract or to any benefit that may arise therefrom.

42. Interest of Members, Officers, or Employees and Former Members, Officers, or Employees

No member, officer, or employee of the PHA, no member of the governing body of the locality in which the project is situated, no member of the governing body of the locality in which the PHA was activated, and no other public official of such locality or localities who exercises any functions or responsibilities with respect to the project, shall, during his or her tenure, or for one year thereafter, have any interest, direct or indirect, in this contract or the proceeds thereof.

43. Limitations on Payments made to Influence Certain Federal Financial Transactions

- (a) The Contractor agrees to comply with Section 1352 of Title 31, United States Code which prohibits the use of Federal appropriated funds to pay any person for influencing or attempting to influence an officer or employee of any agency, a Member of Congress, and officer or employee of Congress, or an employee of a Member of Congress in connection with any of the following covered Federal actions: the awarding of any Federal contract; the making of any Federal grant; the making of any Federal loan; the entering into of any cooperative agreement; or the modification of any Federal contract, grant, loan, or cooperative agreement.
- (b) The Contractor further agrees to comply with the requirement of the Act to furnish a disclosure (OMB Standard Form LLL, Disclosure of Lobbying Activities) if any funds other than Federal appropriated funds (including profit or fee received under a covered Federal transaction) have been paid, or will be paid, to any person for influencing or attempting to influence an officer or employee of any agency, a Member of Congress, an officer or employee of Congress, or an employee of a Member of Congress in connection with a Federal contract, grant, loan, or cooperative agreement.

44. Royalties and Patents

The Contractor shall pay all royalties and license fees. It shall defend all suits or claims for infringement of any patent rights and shall save the PHA harmless from loss on account thereof, except that the PHA shall be responsible for all such loss when a particular design, process or the product of a particular manufacturer or manufacturers is specified and the Contractor has no reason to believe that the specified design, process, or product is an infringement. If, however, the Contractor has reason to believe that any design, process or product specified is an infringement of a patent, the Contractor shall promptly notify the Contracting Officer. Failure to give such notice shall make the Contractor responsible for resultant loss.

45. Examination and Retention of Contractor's Records

- (a) The PHA, HUD, or Comptroller General of the United States, or any of their duly authorized representatives shall, until 3 years after final payment under this contract, have access to and the right to examine any of the Contractor's directly pertinent books, documents, papers, or other records involving transactions related to this contract for the purpose of making audit, examination, excerpts, and transcriptions.
- (b) The Contractor agrees to include in first-tier subcontracts under this contract a clause substantially the same as paragraph (a) above. "Subcontract," as used in this clause, excludes purchase orders not exceeding \$10,000.
- (c) The periods of access and examination in paragraphs (a) and (b) above for records relating to (1) appeals under the Disputes clause of this contract, (2) litigation or settlement of claims arising from the performance of this contract, or (3) costs and expenses of this contract to which the PHA, HUD, or Comptroller General or any of their duly authorized representatives has taken exception shall continue until disposition of such appeals, litigation, claims, or exceptions.

46. Labor Standards - Davis-Bacon and Related Acts

If the total amount of this contract exceeds \$2,000, the Federal labor standards set forth in the clause below shall apply to the development or construction work to be performed under the contract.

- (a) Minimum Wages.
 - (1) All laborers and mechanics employed under this contract in the development or construction of the project(s) involved will be paid unconditionally and not less often than once a week, and without subsequent deduction or rebate on any account (except such payroll deductions as are permitted by regulations issued by the Secretary of Labor under the Copeland Act (29 CFR Part 3)), the full amount of wages and bona fide fringe benefits (or cash equivalents thereof) due at time of payment computed at rates not less than those contained in the wage determination of the Secretary of Labor which is attached hereto and made a part hereof, regardless of any contractual relationship which may be alleged to exist between the Contractor and such laborers and mechanics. Contributions made or costs reasonably anticipated for bona fide fringe benefits under Section 1(b)(2) of the Davis-Bacon Act on behalf of laborers or mechanics are considered wages paid to such laborers or mechanics, subject to the provisions of 29 CFR 5.5(a)(1)(iv); also, regular contributions made or costs incurred for more than a weekly period (but not less often than quarterly) under plans, funds, or programs which cover the regular weekly period, are deemed to be constructively made or incurred during such weekly period. Such laborers and mechanics shall be paid the appropriate wage rate and fringe benefits in the wage determination for the classification of work actually performed, without regard to skill, except as provided in 29 CFR 5.5(a)(4). Laborers or mechanics performing work in more than one classification may be compensated at the rate specified for each classification for the time actually worked therein; provided, that the employer's payroll records accurately set forth the time spent in each classification in which work is performed. The wage determination (including any additional classification and wage rates conformed under 29 CFR 5.5(a)(1)(ii) and the Davis-Bacon poster (WH-1321) shall

be posted at all times by the Contractor and its subcontractors at the site of the work in a prominent and accessible place where it can be easily seen by the workers.

- (2) (i) Any class of laborers or mechanics, including helpers, which is not listed in the wage determination and which is to be employed under the contract shall be classified in conformance with the wage determination. HUD shall approve an additional classification and wage rate and fringe benefits therefor only when all the following criteria have been met: (A) The work to be performed by the classification requested is not performed by a classification in the wage determination; and (B) The classification is utilized in the area by the construction industry; and (C) The proposed wage rate, including any bona fide fringe benefits, bears a reasonable relationship to the wage rates contained in the wage determination.
- (ii) If the Contractor and the laborers and mechanics to be employed in the classification (if known), or their representatives, and HUD or its designee agree on the classification and wage rate (including the amount designated for fringe benefits where appropriate), a report of the action taken shall be sent by HUD or its designee to the Administrator of the Wage and Hour Division, Employee Standards Administration, U.S. Department of Labor, Washington, DC 20210. The Administrator, or an authorized representative, will approve, modify, or disapprove every additional classification action within 30 days of receipt and so advise HUD or its designee or will notify HUD or its designee within the 30-day period that additional time is necessary.
- (iii) In the event the Contractor, the laborers or mechanics to be employed in the classification or their representatives, and HUD or its designee do not agree on the proposed classification and wage rate (including the amount designated for fringe benefits, where appropriate), HUD or its designee shall refer the questions, including the views of all interested parties and the recommendation of HUD or its designee, to the Administrator of the Wage and Hour Division for determination. The Administrator, or an authorized representative, will issue a determination within 30 days of receipt and so advise HUD or its designee or will notify HUD or its designee within the 30-day period that additional time is necessary.
- (iv) The wage rate (including fringe benefits where appropriate) determined pursuant to subparagraphs (a)(2)(ii) or (iii) of this clause shall be paid to all workers performing work in the classification under this contract from the first day on which work is performed in classification.
- (3) Whenever the minimum wage rate prescribed in the contract for a class of laborers or mechanics includes a fringe benefit which is not expressed as an hourly rate, the Contractor shall either pay the benefit as stated in the wage determination or shall pay another bona fide fringe benefit or an hourly cash equivalent thereof.
- (4) If the Contractor does not make payments to a trustee or other third person, the Contractor may consider as part of the wages of any laborer or mechanic the

amount of any costs reasonably anticipated in providing bona fide fringe benefits under a plan or program; provided, that the Secretary of Labor has found, upon the written request of the Contractor, that the applicable standards of the Davis-Bacon Act have been met. The Secretary of Labor may require the Contractor to set aside in a separate account assets for the meeting of obligations under the plan or program.

- (b) Withholding of funds. HUD or its designee shall, upon its own action or upon written request of an authorized representative of the Department of Labor, withhold or cause to be withheld from the Contractor under this contract or any other Federal contract with the same prime Contractor, or any other Federally-assisted contract subject to Davis-Bacon prevailing wage requirements, which is held by the same prime Contractor, so much of the accrued payments or advances as may be considered necessary to pay laborers and mechanics, including apprentices, trainees, and helpers, employed by the Contractor or any subcontractor the full amount of wages required by the contract. In the event of failure to pay any laborer or mechanic, including any apprentice, trainee, or helper, employed or working in the construction or development of the project, all or part of the wages required by the contract, HUD or its designee may, after written notice to the Contractor, take such action as may be necessary to cause the suspension of any further payment, advance, or guarantee of funds until such violations have ceased. HUD or its designee may, after written notice to the Contractor, disburse such amounts withheld for and on account of the Contractor or subcontractor to the respective employees to whom they are due.
- (c) Payrolls and basic records.
- (1) Payrolls and basic records relating thereto shall be maintained by the Contractor during the course of the work and preserved for a period of three years thereafter for all laborers and mechanics working in the construction or development of the project. Such records shall contain the name, address, and social security number of each such worker, his or her correct classification, hourly rates of wages paid (including rates of contributions or costs anticipated for bona fide fringe benefits or cash equivalents thereof of the types described in section 1(b)(2)(B) of the Davis-Bacon Act), daily and weekly number of hours worked, deductions made, and actual wages paid. Whenever the Secretary of Labor has found, under 29 CFR 5.5(a)(1)(iv), that the wages of any laborer or mechanic include the amount of costs reasonably anticipated in providing benefits under a plan or program described in section 1(b)(2)(B) of the Davis-Bacon Act, the Contractor shall maintain records which show that the commitment to provide such benefits is enforceable, that the plan or program is financially responsible, and that the plan or program has been communicated in writing to the laborers or mechanics affected, and records which show the costs anticipated or the actual cost incurred in providing such benefits. Contractors employing apprentices or trainees under approved programs shall maintain written evidence of the registration of apprenticeship programs and certification of trainee programs, the registration of the apprentices and trainees, and the ratios and wage rates prescribed in the applicable programs.

- (2) (i) The Contractor shall submit weekly for each week in which any contract work is performed a copy of all payrolls to the Contracting Officer for transmission to HUD or its designee. The payrolls submitted shall set out accurately and completely all of the information required to be maintained under subparagraph (c)(1) of this clause. This information may be submitted in any form desired. Optional Form WH-347 (Federal Stock Number 029-005-00014-1) is available for this purpose and may be purchased from the Superintendent of Documents, U.S. Government Printing Office, Washington, D.C. 20402. The Contractor is responsible for the submission of copies of payrolls by all subcontractors. (Approved by the Office of Management and Budget under OMB Control Number 1214-0149.)
- (ii) Each payroll submitted shall be accompanied by a "Statement of Compliance," signed by the Contractor or subcontractor or his or her agent who pays or supervises the payment of the persons employed under the contract and shall certify the following:
- (A) That the payroll for the payroll period contains the information required to be maintained under paragraph (c) (1) of this clause and that such information is correct and complete;
- (B) That each laborer or mechanic (including each helper, apprentice, and trainee) employed on the contract during the payroll period has been paid the full weekly wages earned, without rebate, either directly or indirectly, and that no deductions have been made either directly or indirectly from the full wages earned, other than permissible deductions as set forth in 29 CFR Part 3; and
- (C) That each laborer or mechanic has been paid not less than the applicable wage rates and fringe benefits or cash equivalents for the classification of work performed, as specified in the applicable wage determination incorporated into the contract.
- (iii) The weekly submission of a properly executed certification set forth on the reverse side of Optional Form WH-347 shall satisfy the requirements for submission of the "Statement of Compliance" required by subparagraph (c)(2)(ii) of this clause.
- (iv) The falsification of any of the above certifications may subject the Contractor or subcontractor to civil or criminal prosecution under Section 1001 of Title 18 and Section 3729 of Title 31 of the United States Code.
- (3) The Contractor or subcontractor shall make the records required under subparagraph (c)(1) available for inspection, copying, or transcription by authorized representatives of HUD or its designee, the Contracting Officer, or the Department of Labor and shall permit such representatives to interview employees during working hours on the job. If the Contractor or subcontractor fails to submit the required records or to make them available, HUD or its designee may, after written notice to the Contractor, take such action as may be necessary to cause the suspension of any further payment, advance, or guarantee of funds. Furthermore, failure to submit the required records upon request or to

make such records available may be grounds for debarment action pursuant to 29 CFR 5.12.

- (d) (1) Apprentices. Apprentices will be permitted to work at less than the predetermined rate for the work they performed when they are employed pursuant to and individually registered in a bona fide apprenticeship program registered with the U.S. Department of Labor, Employment and Training Administration, Office of Apprenticeship and Training, Employer and Labor Services (OATELS), or with a State Apprenticeship Agency recognized by OATELS, or if a person is employed in his or her first 90 days of probationary employment as an apprentice in such an apprenticeship program, who is not individually registered in the program, but who has been certified by OATELS or a State Apprenticeship Agency (where appropriate) to be eligible for probationary employment as an apprentice. The allowable ratio of apprentices to journeymen on the job site in any craft classification shall not be greater than the ratio permitted to the Contractor as to the entire work force under the registered program. Any worker listed on a payroll at an apprentice wage rate, who is not registered or otherwise employed as stated in this paragraph, shall be paid not less than the applicable wage rate on the wage determination for the classification of work actually performed. In addition, any apprentice performing work on the job site in excess of the ratio permitted under the registered program shall be paid not less than the applicable wage rate on the wage determination for the work actually performed. Where a contractor is performing construction on a project in a locality other than that in which its program is registered, the ratios and wage rates (expressed in percentages of the journeyman's hourly rate) specified in the Contractor's or subcontractor's registered program shall be observed. Every apprentice must be paid at not less than the rate specified in the registered program for the apprentice's level of progress, expressed as a percentage of the journeyman hourly rate specified in the applicable wage determination. Apprentices shall be paid fringe benefits in accordance with the provisions of the apprenticeship program. If the apprenticeship program does not specify fringe benefits, apprentices must be paid the full amount of fringe benefits listed on the wage determination for the applicable classification. If the Administrator of the Wage and Hour Division determines that a different practice prevails for the applicable apprentice classification, fringes shall be paid in accordance with that determination. In the event OATELS, or a State Apprenticeship Agency recognized by OATELS, withdraws approval of an apprenticeship program, the Contractor will no longer be permitted to utilize apprentices at less than the applicable predetermined rate for the work performed until an acceptable program is approved.
- (2) Trainees. Except as provided in 29 CFR 5.16, trainees will not be permitted to work at less than the predetermined rate for the work performed unless they are employed pursuant to and individually registered in a program which has received prior approval, evidenced by formal certification by the U.S. Department of Labor, Employment and Training Administration. The ratio of trainees to journeymen on the job site shall not be greater than permitted under

the plan approved by the Employment and Training Administration. Every trainee must be paid at not less than the rate specified in the approved program for the trainee's level of progress, expressed as a percentage of the journeyman hourly rate specified in the applicable wage determination. Trainees shall be paid fringe benefits in accordance with the provisions of the trainee program. If the trainee program does not mention fringe benefits, trainees shall be paid the full amount of fringe benefits listed in the wage determination unless the Administrator of the Wage and Hour Division determines that there is an apprenticeship program associated with the corresponding journeyman wage rate in the wage determination which provides for less than full fringe benefits for apprentices. Any employee listed on the payroll at a trainee rate who is not registered and participating in a training plan approved by the Employment and Training Administration shall be paid not less than the applicable wage rate in the wage determination for the classification of work actually performed. In addition, any trainee performing work on the job site in excess of the ratio permitted under the registered program shall be paid not less than the applicable wage rate in the wage determination for the work actually performed. In the event the Employment and Training Administration withdraws approval of a training program, the Contractor will no longer be permitted to utilize trainees at less than the applicable predetermined rate for the work performed until an acceptable program is approved.

- (3) Equal employment opportunity. The utilization of apprentices, trainees, and journeymen under this clause shall be in conformity with the equal employment opportunity requirements of Executive Order 11246, as amended, and 29 CFR Part 30.
- (e) Compliance with Copeland Act requirements. The Contractor shall comply with the requirements of 29 CFR Part 3, which are hereby incorporated by reference in this contract.
- (f) Contract termination; debarment. A breach of this contract clause may be grounds for termination of the contract and for debarment as a Contractor and a subcontractor as provided in 29 CFR 5.12.
- (g) Compliance with Davis-Bacon and related Act requirements. All rulings and interpretations of the Davis-Bacon and related Acts contained in 29 CFR Parts 1, 3, and 5 are herein incorporated by reference in this contract.
- (h) Disputes concerning labor standards. Disputes arising out of the labor standards provisions of this clause shall not be subject to the general disputes clause of this contract. Such disputes shall be resolved in accordance with the procedures of the Department of Labor set forth in 29 CFR Parts 5, 6, and 7. Disputes within the meaning of this clause include disputes between the Contractor (or any of its subcontractors) and the PHA, HUD, the U.S. Department of Labor, or the employees or their representatives.
- (i) Certification of eligibility.
 - (1) By entering into this contract, the Contractor certifies that neither it (nor he or she) nor any person or firm who has an interest in the Contractor's firm is a person or firm ineligible to be awarded contracts by the United States Government by virtue of section 3(a) of the Davis-Bacon Act or 29 CFR 5.12(a)(1).

- (2) No part of this contract shall be subcontracted to any person or firm ineligible for award of a United States Government contract by virtue of section 3(a) of the Davis-Bacon Act or 29 CFR 5.12(a)(1).
 - (3) The penalty for making false statements is prescribed in the U. S. Criminal Code, 18 U.S.C. 1001.
- (j) Contract Work Hours and Safety Standards Act. As used in this paragraph, the terms "laborers" and "mechanics" include watchmen and guards.
 - (1) Overtime requirements. No contractor or subcontractor contracting for any part of the contract work which may require or involve the employment of laborers or mechanics, including watchmen and guards, shall require or permit any such laborer or mechanic in any workweek in which the individual is employed on such work to work in excess of 40 hours in such workweek unless such laborer or mechanic receives compensation at a rate not less than one and one-half times the basic rate of pay for all hours worked in excess of 40 hours in such workweek.
 - (2) Violation; liability for unpaid wages; liquidated damages. In the event of any violation of the provisions set forth in subparagraph (j)(1) of this clause, the Contractor and any subcontractor responsible therefor shall be liable for the unpaid wages. In addition, such Contractor and subcontractor shall be liable to the United States (in the case of work done under contract for the District of Columbia or a territory, to such District or to such territory), for liquidated damages. Such liquidated damages shall be computed with respect to each individual laborer or mechanic (including watchmen and guards) employed in violation of the provisions set forth in subparagraph (j)(1) of this clause, in the sum of \$10 for each calendar day on which such individual was required or permitted to work in excess of the standard workweek of 40 hours without payment of the overtime wages required by provisions set forth in subparagraph (j)(1) of this clause.
 - (3) Withholding for unpaid wages and liquidated damages. HUD or its designee shall upon its own action or upon written request of an authorized representative of the Department of Labor withhold or cause to be withheld, from any moneys payable on account of work performed by the Contractor or subcontractor under any such contract or any Federal contract with the same prime Contractor, or any other Federally-assisted contract subject to the Contract Work Hours and Safety Standards Act, which is held by the same prime Contractor, such sums as may be determined to be necessary to satisfy any liabilities of such Contractor or subcontractor for unpaid wages and liquidated damages as provided in the provisions set forth in subparagraph (j)(2) of this clause.
 - (k) Subcontracts. The Contractor or subcontractor shall insert in any subcontracts all the provisions contained in this clause, and such other clauses as HUD or its designee may by appropriate instructions require, and also a clause requiring the subcontractors to include these provisions in any lower tier subcontracts. The prime Contractor shall be responsible for the compliance by any subcontractor or lower tier subcontractor with all these provisions.

47. Non-Federal Prevailing Wage Rates

- (a) Any prevailing wage rate (including basic hourly rate and any fringe benefits), determined under State or tribal law to be prevailing, with respect to any employee in any trade or position employed under the contract, is inapplicable to the contract and shall not be enforced against the Contractor or any subcontractor, with respect to employees engaged under the contract whenever such non-Federal prevailing wage rate exceeds:
 - (1) The applicable wage rate determined by the Secretary of Labor pursuant to the Davis-Bacon Act (40 U.S.C. 3141 et seq.) to be prevailing in the locality with respect to such trade;
- (b) An applicable apprentice wage rate based thereon specified in an apprenticeship program registered with the U.S. Department of Labor (DOL) or a DOL-recognized State Apprenticeship Agency; or
- (c) An applicable trainee wage rate based thereon specified in a DOL-certified trainee program.

48. Procurement of Recovered Materials.

- (a) In accordance with Section 6002 of the Solid Waste Disposal Act, as amended by the Resource Conservation and Recovery Act, the Contractor shall procure items designated in guidelines of the Environmental Protection Agency (EPA) at 40 CFR Part 247 that contain the highest percentage of recovered materials practicable, consistent with maintaining a satisfactory level of competition. The Contractor shall procure items designated in the EPA guidelines that contain the highest percentage of recovered materials practicable unless the Contractor determines that such items: (1) are not reasonably available in a reasonable period of time; (2) fail to meet reasonable performance standards, which shall be determined on the basis of the guidelines of the National Institute of Standards and Technology, if applicable to the item; or (3) are only available at an unreasonable price.
- (b) Paragraph (a) of this clause shall apply to items purchased under this contract where: (1) the Contractor purchases in excess of \$10,000 of the item under this contract; or (2) during the preceding Federal fiscal year, the Contractor: (i) purchased any amount of the items for use under a contract that was funded with Federal appropriations and was with a Federal agency or a State agency or agency of a political subdivision of a State; and (ii) purchased a total of in excess of \$10,000 of the item both under and outside that contract.



**REQUEST FOR BIDS
MBE / WBE PARTICIPATION REPORT**

PARTICIPATION REPORT

MINORITY BUSINESS ENTERPRISE (MBE) WOMEN BUSINESS ENTERPRISE (WBE)

Contract / PO#: _____

Please list below the names of all firmly committed MBE and WBE subcontractors that will work on the project, their MBE/WBE Status, the dollar amount, and the percentage of total contract amount that will be performed by the entities. The MBE/WBE participation can include subcontracts or purchases of services, materials and supplies directly related to the contract.

(Please check one) _____ Proposed _____ Amended _____ Final

	MBE	WBE	Name of Subcontractor(s)	Contract Amount	
				\$ Amount	% Percentage
1	<input type="checkbox"/>	<input type="checkbox"/>	_____	\$ _____	_____ %
2	<input type="checkbox"/>	<input type="checkbox"/>	_____	\$ _____	_____ %
3	<input type="checkbox"/>	<input type="checkbox"/>	_____	\$ _____	_____ %
4	<input type="checkbox"/>	<input type="checkbox"/>	_____	\$ _____	_____ %
5	<input type="checkbox"/>	<input type="checkbox"/>	_____	\$ _____	_____ %
6	<input type="checkbox"/>	<input type="checkbox"/>	_____	\$ _____	_____ %
7	<input type="checkbox"/>	<input type="checkbox"/>	_____	\$ _____	_____ %
8	<input type="checkbox"/>	<input type="checkbox"/>	_____	\$ _____	_____ %
9	<input type="checkbox"/>	<input type="checkbox"/>	_____	\$ _____	_____ %
10	<input type="checkbox"/>	<input type="checkbox"/>	_____	\$ _____	_____ %
11	<input type="checkbox"/>	<input type="checkbox"/>	_____	\$ _____	_____ %
12	<input type="checkbox"/>	<input type="checkbox"/>	_____	\$ _____	_____ %
Total MBE Dollar Amount and Percentage of Contract				\$ _____	_____ %
Total WBE Dollar Amount and Percentage of Contract				\$ _____	_____ %

Fill with legible block letters

Signature: _____

Contact Person: _____

Company Name: _____

Date: _____



**REQUEST FOR BIDS
SECTION 3 RESIDENTS AND BUSINESS CONCERNS**

S3 RESIDENTS AND BUSINESS CONCERNS

MINORITY BUSINESS ENTERPRISE (MBE) & WOMEN BUSINESS ENTERPRISE (WBE)

Prospective Business Vendor:

Section 3 is a provision of the Housing and Urban Development (HUD) Act of 1968 that helps foster local economic development, neighborhood economic improvement, and individual self-sufficiency. The Section 3 program requires that recipients of certain HUD financial assistance, to the greatest extent feasible, provide job training, employment, and contracting opportunities for low- or very low-income residents in connection with projects and activities in their neighborhoods.

Anyone claiming to be a Section 3 Business Concern shall be required, as set forth by procedure, to provide evidence of such status. Section 3 Business Concerns claiming Section 3 Preference status must meet that status at the time the bid, Bid or proposal is submitted to CMHA.

If you need any assistance or help regarding Section 3, feel free to contact us at Section3@cintimha.com

Section 3 Clause

- A. The work to be performed under this contract is subject to the requirements of section 3 of the Housing and Urban Development Act of 1968, as amended, 12 U.S.C. 1701u (section 3). The purpose of section 3 is to ensure that employment and other economic opportunities generated by HUD assistance or HUD-assisted projects covered by section 3, shall, to the greatest extent feasible, be directed to low- and very low-income persons, particularly persons who are recipients of HUD assistance for housing.
- B. The parties to this contract agree to comply with HUD's regulations in 24 CFR part 75, which implement section 3. As evidenced by their execution of this contract, the parties to this contract certify that they are under no contractual or other impediment that would prevent them from complying with the part 75 regulations.
- C. The contractor agrees to send to each labor organization or representative of workers with which the contractor has a collective bargaining agreement or other understanding, if any, a notice advising the labor organization or workers' representative of the contractor's commitments under this section 3 clause, and will post copies of the notice in conspicuous places at the work site where both employees and applicants for training and employment positions can see the notice. The notices shall describe the section 3 preference, shall set forth minimum number and job titles subject to hire, availability of apprenticeship and training positions, the qualifications for each; and the name and location of the person(s) taking applications for each of the positions; and the anticipated date the work shall begin.



REQUEST FOR BIDS
SECTION 3 RESIDENTS AND BUSINESS CONCERNS

- D. The contractor agrees to include this section 3 clause in every subcontract subject to compliance with regulations in 24 CFR part 75, and agrees to take appropriate action, as provided in an applicable provision of the subcontract or in this section 3 clause, upon a finding that the subcontractor is in violation of the regulations in 24 CFR part 75. The contractor will not subcontract with any subcontractor where the contractor has notice or knowledge that the subcontractor has been found in violation of the regulations in 24 CFR part 75.
- E. The contractor will certify that any vacant employment positions, including training positions, that are filled (1) after the contractor is selected but before the contract is executed, and (2) with persons other than those to whom the regulations of 24 CFR part 75.9 require employment opportunities to be directed, were not filled to circumvent the contractor's obligations under 24 CFR part 75.9
- F. Noncompliance with HUD's regulations in 24 CFR part 75 may result in sanctions, termination of this contract for default, and debarment or suspension from future HUD assisted contracts.
- G. In the event of a determination by the Executive Director or his/her designee that the Contractor is not in compliance with the section 3 clause or any rule, regulation, or report submission requirements of the CMHA, this contract may be canceled, terminated, or suspended in whole or in part, and the Contractor may be declared ineligible for further CMHA contracts for a period of one to three years.
- H. Section 3. The work to be performed under this Agreement is subject to the requirements of Section 3. The Parties agree to comply with HUD's regulations in 24 C.F.R. part 75, which implement Section 3 and hereby certify to the best of their knowledge that they are under no contractual or other impediment that would prevent them from compliance. The Authority shall monitor the Developer's compliance from time to time during the Project. The Developer agrees to require all Subcontractors to the greatest extent feasible to comply with Section 3 and the regulations promulgated in 24 C.F.R. part 75, and agrees to take appropriate action upon a finding that the Subcontractor is in violation of the regulations in 24 C.F.R. part 75. The Developer will not contract with any Subcontractor where the Developer has notice or knowledge that the Subcontractor has been found in violation of the regulations in 24 C.F.R. part 75.
- I. Number. The Developer agrees to meet the following Section 3 benchmarks of 25/5 (25% Section 3 Total Labor Hours / 5% Targeted Section 3 Total Labor Hours) and the stated percentages when selecting Subcontractors for the Project: (i) at least twenty percent (20%) of the general construction Subcontractors to qualify as a MBE Subcontractor; (ii) at least five percent (5%) of the general construction to qualify as a MBE Subcontractor (iii) at least ten percent (10%) of the construction contract Subcontractors to qualify as Section 3 Subcontractors. Additionally, any hiring or training opportunities generated should be provided to Section 3 and Targeted Section 3 workers to the greatest extent feasible. The list of proposed Subcontractors, including the MBE, WBE and Section 3 Subcontractors, shall be submitted to the Authority for approval prior to the Closing.



REQUEST FOR BIDS SECTION 3 RESIDENTS AND BUSINESS CONCERNS

- J. CMHA is committed to fostering neighborhood economic improvement and the self-sufficiency of its residents. This is done through taking proactive steps to hire local low-income persons and to award contractors to business that are registered Section 3 businesses. Therefore, CMHA strives to ensure that at least fifteen percent (15%) of all subcontracts are awarded to Section 3 businesses.
- K. In accordance with the findings of the Congress, as stated in section 3, that other economic opportunities offer an effective means of empowering low-income persons, a recipient is encouraged to undertake efforts to provide to low-income persons economic opportunities other than training, employment, and contract awards, in connection with section 3 covered assistance.
- L. The Developer shall require all Subcontractors to send to each labor organization or representatives of workers with which such Subcontractor has a collective bargaining agreement or other understanding, if any, a notice advising the labor organization or workers' representative of the Developer's and/or Subcontractor's commitments under Section 3, and will post copies of the notice in conspicuous places at the work site where both employees and applicants for training and employment positions can see the notice. Each Subcontractor shall certify to the Developer that any vacant employment positions, including training positions, that are filled (i) after a Subcontractor is selected but before the relevant contract is executed and (ii) with persons other than those to whom the regulations of 24 C.F.R. Part 75 require employment opportunities to be directed, were not filled to circumvent the Subcontractor's obligations under 24 C.F.R. Part 75 and the Developer shall certify to the Authority that it has obtained all such certifications.
- M. With respect to work performed in connection with section 3 covered Indian housing assistance, section 7(b) of the Indian Self-Determination and Education Assistance Act (25 U.S.C. 450e) also applies to the work to be performed under this contract. Section 7(b) requires that to the greatest extent feasible (i) preference and opportunities for training and employment shall be given to Indians, and (ii) preference in the award of contracts and subcontracts shall be given to Indian organizations and Indian-owned Economic Enterprises. Parties to this contract that are subject to the provisions of section 3 and section 7(b) agree to comply with section 3 to the maximum extent feasible, but not in derogation of compliance with section 7(b).

Assurance of Compliance Training, Employment, and Contracting Opportunities

The project assisted under this contract is subject to the requirements of Section 3 of the Housing and Urban Development Act of 1968, as amended, 12 U.S.C. 170u. Section 3 requires that to the greatest extent feasible, newly created opportunities that are generated by the awarding of this contract be given to:

- Section 3 Workers (25% minimum goal of labor hours) upon their qualifications.
- Section 3 Targeted Workers (5% Minimum of labor hours)

Notwithstanding any other provision of this contract, the applicant shall carry out the provisions of said Section 3 and the regulations issued pursuant thereto by the Secretary set forth in 24 CFR Part 75, and all applicable rules and orders of the Secretary issued thereunder prior to the execution of this contract. The



REQUEST FOR BIDS SECTION 3 RESIDENTS AND BUSINESS CONCERNS

requirements of said regulations include but are not limited to development and implementation of a Section 3 Action Plan/Strategy for utilizing Section 3 Business Concerns; the making of a good faith effort, as defined by the regulation, to provide training, employment and business opportunities required by Section 3; and incorporation of the “Section 3 Clause” specified by Section 75.9 and 75.17 of the regulations in all contracts for work in connection with the project. The applicant and recipient agency, certifies and agrees that it is under no contractual or other disability which would prevent it from complying with these requirements.

Compliance with the provision of Section 3, the regulations set forth in 24 CFR Part 75, and all applicable rules and orders of the Secretary issued thereunder prior to approval by the Government of the application of this contract, shall be a condition of the Federal financial assistance provided to the project, binding upon the applicant, its contractors and subcontractors, its successors, and assigns to the sanctions specified by the contract, and to such sanctions as are specified by 24 CFR Section 75.

Action Plan Submission

The Section 3 Action Plan is a requirement for contracting opportunities with CMHA. The Section 3 Action Plan must indicate/describe the proposed strategies for achieving the Section 3 training and/or employment goals, and subcontracting numerical goals, when and if newly created opportunities are generated upon awarding of contracts. Failure to submit the Section 3 Action plan may jeopardize the proposal/bid up to and including the possibility of said proposal/bid being deemed non-responsive.

Please review and complete the Section 3 Action Plan - Opportunities Strategies in the *Bid*. All Sections need to be completed. This information will help to assist you in formulating your Section 3 Action Plan. You will need to address each question and check the appropriate boxes in regards to how your company will strive to achieve Section 3 Compliance to the “greatest extent feasible”. Please identify individual(s) responsible for planning, implementing and tracking the projects’ Section 3 training, employment and/or contracting goals.



**REQUEST FOR BIDS
PREVAILING WAGES CLAUSE**

TO THE CINCINNATI METROPOLITAN HOUSING AUTHORITY (CMHA)

In submitting this Bid, I acknowledge that:

- A. The Prevailing Wages shall be paid for a legal day's work to laborers, workmen or mechanics engaged in work under this Contract, at the site of the Project, in the trade or occupation listed.
- B. The Wage Determinations provided shall be closely monitored by the contractor/bidder/Proposer for any modifications until the actual construction work begins locking in the wage determination for the duration of the contract. Wage determinations and modifications can be monitored and obtained at www.wdol.gov. Failure to include the current wage determination will not relieve the contractors of potential wage liabilities.
- C. It shall be the Prime Contractor's responsibility to verify the accuracy of the reported wages, including his subcontractors.
- D. It shall be the Contractors responsibility to be certain that all the classifications needed to accomplish the contract fall underneath one of the classifications listed on the Wage Determination provided in the scope of work.
- E. In the event that a required classification is not listed, a contractor may submit a request for an additional classification. Remember the request is not valid unless the Department of Labor approves it. There will be no justification for an adjustment to a contract price due to an increased wage rate. The contractor should have been aware of any particular skilled trades that were not included in the original wage determination and thus accepted any risk that DOL would "conform" a pay rate higher than what they estimated when they priced their proposal. The contractor is responsible to propose wage/benefit rates that "bear a reasonable relationship" to the other classifications and rates listed on the wage determination.
- F. The following pages are the Prevailing Rates of Wages as ascertained by the State or other Agency for this Project.
- G. Listed below is a checklist of items required for Wage and Hour Compliance.
- H. Remember, prompt correction of deficiencies is essential. Failure to correct in a timely manner will be the withholding of payments on your contract until the deficiencies are corrected.



**REQUEST FOR BIDS
PREVAILING WAGES CLAUSE**

I. For your convenience listed below is a checklist of items required:

- Appointment of Paymaster
- Equal Employment Opportunity Affirmative Action Policy Statement (*EEOAAPS*)
- Equal Employment Opportunity Compliance Certificate (*EEOCC*)
- Letter of Understanding
- General and Subcontractors form (*if applicable*)
- Employment Utilization Report (*upon completion*)
- Section 3 Form (*if applicable*)
- Weekly certified payrolls that include:
 - Contractor's Name
 - Contractor's Address
 - Payroll #
 - Week Ending Date
 - Project and Location
 - Contract or Purchase Order No.
 - Name of Employee
 - Social Security Number
 - Address of Employee
 - No. of Exemptions
 - Work Classification
 - Calendar Days
 - Hours Worked
 - Total Hours
 - Rate of Pay
 - Gross Amount Earned
 - Taxes or Write 1099 across columns if employee files his own taxes
 - Statement of Compliance (back page of the payroll sheet)
 - One of the boxes checked indicating if fringes benefits are paid in cash or approved program
 - Contract's Signature Certifying Payroll

Fill with legible block letters

Signature: _____

Contact Person: _____

Company Name: _____

Date: _____



REQUEST FOR BIDS SCOPE OF WORK

PART 1 ADMINISTRATIVE

1.1 GENERAL

A. Gold Standard

In 2012, CMHA established its Gold Performance Standards which consist of the principles and values by which the Agency performs and how our partners, vendors, contractors and consultants are measured.

The Gold Performance Standards are: Respect, Timely, Exceptional, Initiative, Excellent, Quality, Accurate, Integrity, Value, Creativity, Accountability and Professionalism. It's very imperative that our partners, vendors, contractors and consultants abide by these standards that has been establish.

B. CMHA's Vendor Registration

1. The Contractor shall register as a CMHA's Vendor if not one already. To complete CMHA's vendor registration packet visit www.cintimha.com under Business Opportunities / Vendor Registration.

C. Prevailing Wages

1. The Contractor is responsible to consider the Prevailing Wage determination. The Attached Wage Determination can be subject to change from the time of contractor walk through to the date the bid is due. Typically, the wage rates are updated/revised/modified on Friday's every week. To monitor the Wage Determination visit: www.wdol.gov

D. Permits

1. The Contractor Shall Obtain all necessary permits for construction activities in accordance with Federal, State and Local Jurisdiction.

E. Existing conditions

1. The contractor shall field verify all existing condition prior to quoting. Contractor is responsible to examine the job conditions and field measurement, distances, elevations, clearances, etc. and base their quote and work on verified conditions. No Change Order will be approved for modifications/alterations required to existing conditions that are



REQUEST FOR BIDS SCOPE OF WORK

apparent on the drawings and specifications and visible during the walk through.

F. Drawings and Specifications

1. The Contractor is responsible for comprehending the specifications, plans and becoming familiar with the site location and performing/completing all the work in the specifications at high standards in a professional manner.

G. Contract Management

1. The Contractor shall provide a Construction Schedule and all applicable insurances at the Pre-Construction meeting before starting construction.
2. The contractor shall furnish all labor, materials, tools, equipment and devices to complete the work as specified in scope of work.
3. The contractor is responsible pay all utilities during construction ie. electric power, natural gas and water. The contractor shall provide those not available on the property and needed for construction.

H. Site Management

1. The Contractor shall provide the Construction Project Manager and the Property Manager (PM) with 48-hour advance notice prior to the start of work.
2. The Unit will be
 vacant during construction. occupied during construction.
3. The Building will be
 vacant during construction. occupied during construction.
4. Construction working hours are 8:00 a.m. - 4:00 p.m. Monday thru Friday. Weekend work is prohibited if not approved in writing.
5. The Contractor shall coordinate and cooperate with surrounding residents who currently reside in the houses and buildings to minimize conflicts. The contractor is fully responsible for properly securing the house at the end of the work day.
6. The Contractor shall keep areas under construction clean on a daily basis. All un-used construction material shall be removed from site at the end of each work day. The contractor is prohibited from using any dumpsters and/or totters that are on site. The contractor shall clean all areas that are affected by the renovation (i.e. mechanical room,



REQUEST FOR BIDS SCOPE OF WORK

- public walk ways, driveway, etc.)
7. The Contractor shall secure the construction site. The Contractor shall secure and protect all materials, tools and equipment stored on site and all work completed. CMHA assumes no liability for these material, tools and equipment that may become missing and/or damaged and not guarantees that the property's video surveillance captures the incident, if available.
 8. The contractor may store materials, tools and equipment on site if approved in writing and as instructed by the owner.
 9. The contractor shall have at least one person in charge and on site during the duration of the project. This person shall be familiar with the project scope and daily construction activities and other persons in the work area.
 10. The contractor shall maintain all lawns/sites within the area contracted for the duration of the project. Lawns shall be cut a minimum of once every 10 days from March through October. The contractor shall also be responsible for the removal of all rubbish, debris limbs, leaves, etc., within the area.
 11. The Contractor shall coordinate with owner location of barriers and separations as necessary to protect occupied areas from noise, dust or other disruptive activities.
 12. The Contractor shall perform the work with a minimum of disruption by noise, odors, dust or other disruptive causes to owner's normal operations.
 13. The contractor is responsible for any damages that may occur to the existing exterior and interior finish (i.e. landscaping, exterior façade, grass, concrete walks, asphalt/concrete paving, drywall, flooring materials, wall base, wall/door finishes, etc.) during the construction duration.
 14. Protect all adjacent surfaces or finishes during all work. Restore affected surfaces if damaged during construction.
 15. CMHA does not furnish janitorial supplies. However, the contractor is encouraged to contact the CMHA Materials Controls Department or Field Representative to get a list of janitorial products commonly used by CMHA.
 16. The contractor is responsible for all trash and debris in the units, and in the front, sides



REQUEST FOR BIDS SCOPE OF WORK

and rear yards.

I. End of Construction

1. The contractor is to submit an Operation and Maintenance manual at the end of the project, one hard copy and one digital copy in PDF format. The Operation and Maintenance manual shall include manufacturer manual and warranty of all equipment and/or devices used/purchased for this project.
2. The Contractor shall warranty all material and workmanship for a period of one year after acceptance.
3. The contractor shall perform all tests, adjustments, etc. as required by equipment manufacturer.
4. The Contractor shall perform all tests, adjustments, etc. as required on all new installed devices. The equipment and devices are to be 100% operable/functional after installation.

PART 2 CONTRACTOR RESPONSABILITIES

1. The Contractor shall:
 - i. Verify quantities to successfully complete the project.
 - ii. Coordinate with building operations and residents to minimize the interference of day to day activities.
 - iii. Coordinate with building manager location of dumpster.
 - iv. Coordinate with any other contractor working in the building. CMHA has several projects ongoing in this building.
 - v. The contractor or any of its personnel shall not enter any unit, at any time. No exceptions.
 - vi. Smoking is not permitted inside the building or its surrounding areas.
 - vii. Keep all areas clean and free of debris during construction activities and after hours.
 - viii. The contractor, subcontractors, material men, or suppliers shall use only unmanufactured articles, materials, and supplies that have been mined or produced in



REQUEST FOR BIDS SCOPE OF WORK

the United States; and manufactured articles, materials, and supplies that have been manufactured in the United States substantially all from articles, materials, or supplies mined, produced, or manufactured in the United States.

PART 3 MAKE READY PROCEDURES

APPLY

DO NOT APPLY

3.1 GENERAL (All units expect as noted)

A. Preparation and Finishing

2. Remove all hangers, hooks, mails, tape, contact paper, wall paper, borders, etc.
3. Remove any obvious imperfections in walls or ceilings.
4. Remove any imperfections around fixtures of any sort and outlets. Do not paint electrical fixtures, switches, outlets or cover plates.
5. Wipe debris off all surfaces. This includes but is not limited to webs, dust, dirt, insect eggs and feces.
6. Paint all walls, ceilings, doors, window sills, trim, etc.
7. Drywall should be prepped for level 4 drywall finish. This will require drywall to be skim coated to provide smooth finish prior to painting.
8. In the kitchen, wash all surfaces of excessive smoke or grease damage. Special care shall be given to cleaning the area behind the range and refrigerator.
9. Properly use drop clothes.
10. Remove excessive debris and dust from heat registers before painting them.
11. Caulk all edges of countertops, window frames, door frames, kitchen cabinets, the base of all walls that connect apartments and public spaces, etc.
12. Cleaning of paint and drywall utensils and tools of any kind are not permitted in the apartment unit(s).
13. The contractor shall inspect all surfaces requiring painting to verify the work has been completed before turning over the unit as PAINTED.
14. Paint to use:
 - i. Primary wall paint: Promar 200 Interior Latex Eggshell, SW 7015
 - ii. Bathroom paint: Promar 200 Interior Latex Semi-Gloss, SW 7015



REQUEST FOR BIDS SCOPE OF WORK

iii. Ceiling paint: Promar 200 Interior Latex Flat, SW 7006

iv. Door and trim paint: Promar 200 Interior Latex Eggshell, SW 7006

3.2 MAINTENANCE (All units expect as noted)

A. Leaking Faucets

1. All faucets and toilets shall be operable and without leaks.
2. All drains shall be open and without leaking waste lines.
3. Laundry station(s) shall be operable, open and without leaks.

B. Windows

1. Clean all windows, doors, frames and seals, including front and back storm doors, and including handles and knobs. They should open, close and be able to lock.
2. Remove and repair any damage from any old hardware remaining from previous blinds and shades no longer in use.
3. Windows shall have vinyl 1" mini-blinds in working condition.
 - i. All screens should be cleaned and in place without any rips or holes.
4. All missing screen shall receive new matching screens.

C. Doors

1. Make sure that all storm and prime doors are in place and operable (open, close and are able to lock).
2. All doors (interior, exterior, closets and cabinets) must be able to open and close properly without any missing hardware.
3. Replace or repair wheels, tracks, hardware, door knobs, etc. so that doors are operable and function properly.
4. Exterior Doors must be cleaned both on the inside and outside, including screen doors/storm doors.
5. Exterior doors must be painted as necessary.
6. Interior doors must be painted or shellacked as necessary.
7. Check door sweeps and weather stripping. Replace where needed.
8. Install doorstops throughout the unit.



REQUEST FOR BIDS SCOPE OF WORK

9. Busted doors must be replaced. A busted door may consist of veneer coming off, excessive holes, cracks, or anything beyond repair. If the replacement of the door is in question, the property manager will have the final say in determining whether or not to replace it. It is the contractor's responsibility to ensure a proper fit within the frame, the holes are accurately drilled for hinges, door knob and lockset. Should the contractor damage the door during this process, they will be held financially responsible and/or required to replace the door with new like-kind door.
10. Do not paint door hardware, if painted previously paint must be removed.

D. Cover Plates

1. Replace (provide where missing) all cracked or damaged electrical/cable/telephone cover plates.
2. Do not paint cover plates.

E. Stair Treads

1. All stair treads shall be securely in place and without any cracks, chips, breaks or tripping hazards. No tripping hazards.
2. All stair treads must be cleaned thoroughly.

F. Electric Fixtures and Outlets

1. Clean all interior and exterior light fixtures, light shades, globes and switch plates and switches.
2. Fixtures shall be free of fingerprints, marks, dust and insects.
3. All switches shall be operable.
4. All outlets (including GFCI) shall be operable.
5. All exterior light fixtures, doorbells, etc. shall be operable.

G. Smoke Alarms/Detector

1. Remove all smoke alarms/detectors and install new per all applicable codes and regulations.
2. All smoke alarms/detectors should be properly installed and working.
3. Smoke alarms should not be painted or have stickers or other decorations present.
4. Smoke alarm/detector location guidelines



REQUEST FOR BIDS SCOPE OF WORK

- i. If mounted on the ceiling, it must be more than 4 inches from the wall.
- ii. It cannot be closer than 4 inches or more than 12 inches from the ceiling if mounted on the wall.
- iii. Smoke alarms should not be installed near windows, doors, or ducts where drafts might interfere with their operation.

H. Carbon Monoxide (CO) Alarms/Detector

1. Remove all smoke alarms/detectors and install new per all applicable codes and regulations.
2. Carbon Monoxide Detection shall be installed in dwelling units containing a fuel-burning appliance or fireplace.
3. Carbon Monoxide detection shall be included in any dwelling units with attached private garages.
4. Carbon Monoxide detectors shall be installed in dwelling units outside each sleeping area and within 10 ft. of the bedroom. If a fuel-burning appliance is installed in the bedroom, a CO detector must be installed in the bedroom.

I. LVT / VCT Floors

1. In locations where the floor tile terminates between rooms, provide a transition strip.
2. Remove/replace all damaged, missing and/or defective wood/vinyl baseboards, toe strips or transition strips.

J. Ceramic Tile

1. Replace any damaged drywall/green board behind ceramic wall tile.
2. Repair or replace any loose, broken or missing ceramic wall tile. Replace all loose, broken or missing grout (match existing). Remove/replace or provide caulk at all tub/ceramic tile locations that terminate at wall surfaces.

K. Water Heater(s)

1. Inspect water heater(s) for proper operation and exhaust venting. Report any problems to the Owner's Field Representative.
2. Furnace(s) and Boiler(s)



REQUEST FOR BIDS SCOPE OF WORK

3. Inspect furnace(s) for proper operation and exhaust venting. Report any problems to the Owner's Field Representative.
4. Inspect boiler(s) for proper operation and exhaust venting. Report any problems to the Owner's Field Representative.
5. Inspect thermostat(s) for proper operation. Report any problems to the Owner's Field Representative.
6. Vacuum clean all heating and air conditioning equipment, grills, registers, etc. Report any problems (damaged or missing items) to the Owner's Field Representative.

L. Appliances

1. Range Hood – Inspect the range hood for proper operation (fan, light and exhaust venting if required). The hood should have all of its parts and hardware such as filters, knob, etc. Report any problems to the Owner's Field Representative.
2. Range and Refrigerator – The existing ranges and refrigerators on site shall be unwrapped and installed (put in place) and made ready for use (i.e. plugged-into outlet, connected to gas supply piping, etc.). Report any problems to the Owner's Field Representative.
3. Must operate properly with all parts and hardware on it.
4. Gaskets should seal properly
5. All lights must be working

M. Exterior and Unit Entry Doors

1. All doors must open and close securely. All doors shall have proper and functioning hardware. Report any problems to the Owner's Field Representative.
2. Inspect all doors for proper door sweeps and weather stripping. Remove/replace and/or provide new door sweeps and weather stripping where required.
3. Remove/replace and/or provide new door stops throughout all units.

N. Closets

1. Inspect all closets and verify the proper installation of shelving and clothes rods. If any are damaged or missing, report the information to the Owner's Field Representative.
2. Make sure all closet poles and shelves are installed.



REQUEST FOR BIDS SCOPE OF WORK

3. Closets shall be cleaned and free of debris.

O. Stoppers/Strainers

1. Provide a stopper or strainer in every sink.

P. Bathroom Fixtures

1. Inspect all bathrooms to ensure that they have in place a soap dish, towel bars and a medicine cabinet. If any of these items are missing, report this information to the Owner's Field Representative.

Q. Bathroom, Laundry, and Kitchen Cabinetry

1. All elements should be inspected when evaluating cabinets, including doors, drawers, hinges, knobs, drawer guides or slides, shelves, and cases or boxes.

R. Caulking / Sealing of the Unit

1. Caulk where needed on counter tops, window frames, door frames, kitchen cabinets etc.
2. In apartments caulk the base of all walls that connect two units.
3. Caulk around breaker box.
4. IPM (Integrated Pest Management) practices must be followed:
5. Seal all openings, cracks, and voids where possible including but not limited to around conduits and pipes
6. Caulk all baseboards.
7. Caulk between kitchen cabinet trim and cabinets if your I.D. badge can slide between the trim and the cabinet.
8. Secure all loose material to prevent harborages (e.g., loose trim boards, loose hinges, uncaulked trim).
9. Clear silicone must be used inside all cabinets/drawers and where cove base/baseboard meets floor.
10. Paintable caulking must be used where cabinets meet wall and where cove base/baseboard meets wall.
11. All caulking color should match surrounding surface.
12. Any voids larger than ¼" cannot be caulked, additional support is needed, examples:
 - i. ¼" round wood trim



REQUEST FOR BIDS SCOPE OF WORK

- ii. Luan board
- iii. Expandable foam
- iv. Expanded foam must be trimmed or sanded
- v. Various types of wood trim
- vi. Heat tape (range hoods).

S. Painting/Preparation and Finishing

1. Remove all hangers, hooks, nails, tape, contact paper, wallpaper, borders etc.
2. Take out any obvious imperfections in wall or ceilings.
3. Take out imperfections around fixtures of any sort and outlets.
4. DO NOT PAINT electrical fixtures, switches, outlets, cover plates, sprinkler heads, and escutcheon plates.
5. Remove debris and dust from within the heater registers and ductwork.
6. Use caulk where needed on counter tops, window frames, door frames, kitchen cabinet etc.
7. Inspect entire unit before you request approval for painting.

T. Painting

1. All painted surfaces will be repainted to provide a uniform finish and shall be free from runs. Work shall be performed in accordance with all the manufacturer's recommendations. The Contractor will be responsible for correcting at his/her expense any work not accepted by the Authority Staff.
2. Contractor shall scrape off all flaking and/or loose paint from ceiling, walls and trim, interior and exterior doors, and exterior windowsill surfaces. Where chipped paint exists, sanding will be performed by use of various grades of sandpaper to featheredge chipped areas to allow a smooth flow of paint and prevent further chipping.
3. Contractor shall perform surface preparation throughout unit on all walls and surfaces requiring painting for the application of paint; surfaces shall be prepared to be consistent with the existing surface. Contractor will paint the unit in accordance with the terms of this proposal and scope of work.



REQUEST FOR BIDS SCOPE OF WORK

4. All nails, screws, brackets, debris, etc., shall be removed. All holes in the walls, ceilings, doors, trim, etc., as well as cracks, will be properly filled, floated or caulked flush with existing surface. Finish will match all other existing finish work.
5. All doors and window trim must be painted. **DO NOT PAINT BUSTED DOORS.** Busted doors must be replaced, previously described. Doors include but are not limited to interior, exterior, and screen doors.
6. Each unit shall include a painted accent wall in the living room.
7. If range hoods are currently painted, and range hood paint is peeling, flaking or bubbling, paint with heat-retardant paint, or replace range hood. **DO NOT** paint range hoods if not currently painted. Touch up any nicks or scrapes to appliances with appliance paint.
8. **DO NOT** paint electric boxes, breaker boxes, or cover plates unless previously painted.
9. Properly use drop cloths. Improper use could lead to termination of the contract and you will also be held liable for costs to restore floors, stairs, hardwood floors, VCT tile, ceramic tile, etc. Properly clean paint equipment and wall repair materials. Do not clean paint equipment in units. Protect all drains from clogging. Contractor may be held accountable for plumbing costs incurred due to Contractor's actions. **DO NOT** dispose of paint in trash chutes.

3.3 JANITORIAL (All units expect as noted)

A. Bathroom(s)

1. Clean ceramic tile walls and grout.
2. Clean ceramic tile floors and grout where applicable.
3. Clean and disinfect all bathroom fixtures including but not limited to: faucets, sink, toilet, bathtub, grab bars, knobs, medicine cabinet.

B. VCT Floors

1. Stripping Floors:
 - i. Use buffer to strip tile floors.
 - ii. Clean all corners under and/or around heat registers and vents.



REQUEST FOR BIDS SCOPE OF WORK

- iii. Clean baseboards and cove base.
2. Sealing/Waxing:
 - i. Provide two coats of sealer and two coats of wax to the floors.

C. Carpet

1. Contractor shall furnish necessary equipment and materials/supplies to perform any carpet cleaning.
2. Contractor shall vacuum carpets both prior to and after cleaning carpets.
3. Carpet cleaning includes, but is not limited to, cleaning the carpet, spot treatment, moving furniture (if applicable), stain removal and carpet stretching (if required due to the water).

D. Wood floor

1. Clean wood floors and apply polyurethane.

E. Light Fixtures and Globes/Shades

1. Clean all light fixtures, light globes/shades, etc.

F. Windows/Frames and Doors/Frames

1. Clean all windows and frames.
2. Clean all doors and frame.

G. Kitchen

1. Stove
 - i. Clean the outside of the stove with degreasing soap or all-purpose cleaner.
 - ii. Use the degreaser or all-purpose cleaner on the knobs and handles as well.
 - iii. Use oven cleaner for the inside of oven door, inside of broiler, the pan and the oven interior.
 - iv. Clean drip pans and vent filters
 - v. Clean range hood.
2. Walls
 - i. Kitchen walls must be cleaned for excessive smoke or grease damage.
 - ii. The area behind the range must be cleaned as well.
3. Refrigerator



REQUEST FOR BIDS SCOPE OF WORK

- i. Contractor shall defrost, clean and dry refrigerator.
 - ii. Clean refrigerator using an all-purpose cleaner or any other cleaner that does not harm coating or gaskets.
 - iii. Clean excess dust from bottom and rear coil of refrigerator.
4. Cabinets/Sinks/Countertops
 - i. Clean all cabinets inside and outside.
 - ii. Clean sink and countertops.
 - iii. Cabinets, drawers and hinges shall be cleaned and free of debris.
5. Miscellaneous
 - i. Clean the outside of water heater.
 - ii. Contractors must ensure that units with basements are cleaned.
 - iii. Pressure wash garages, both interior and exterior.

3.4 PROTECTION AND CAUTIONS

1. Protect all adjacent surfaces or finishes during all work. Restore affected surfaces if damaged during construction.
2. CMHA does not furnish janitorial supplies. However, the contractor is encouraged to contact the CMHA Materials Controls Department or Field Representative to get a list of janitorial products commonly used by CMHA.
3. The contractor is responsible for all trash and debris in the units, and in the front, sides and rear yards.

PART 4 UFAS STANDARDS



APPLY



DO NOT APPLY.

4.1 Follow all dimensions and clearances for American National Standard Institute (ANSI) ICC A117.1-2009 code compliance.

1. **Bathtub & Shower Controls:** Install controls within the space indicated.
2. **Sinks:** Install all bathroom sinks at or below, as approved, the maximum mounting heights and with floor clearances as indicated.
3. **Closets:** Install double hardware for shelving at 42" and 68". Install shelf at 42".

4. **Blocking for grab bar installation:** Install as indicated on detail. Blocking must be able to support 250 lb. of force applied to the grab bar.
5. **Controls outlets, switches, etc.:** Locate all controls, electrical panels, switches, receptacles and other operable equipment as indicted.
6. **Fixtures:** Mounting heights shall be as indicated.
7. **Kitchen Cabinets:** Install upper cabinets so that the lowest shelf is at a maximum of 48" A.F.F. The countertop height and the rim of the sink height shall be at a maximum of 34" A.F.F.
8. **Kitchen cabinet door pulls & handles:** Install Door pulls or handles for the upper cabinets as close as possible from the bottom of the cabinet door. Install Door pulls or handles for the lower cabinets as close as possible from the top of the cabinet door.
9. Mount all equipment's, fixtures, receptacles, outlets, switches, thermostats and controls as shown.
10. Diagrams below are not to scale.

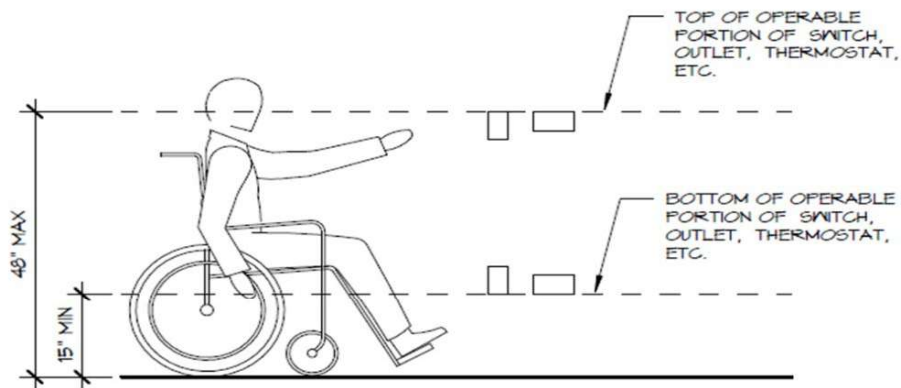

Reach Ranges

REQUEST FOR BIDS SCOPE OF WORK

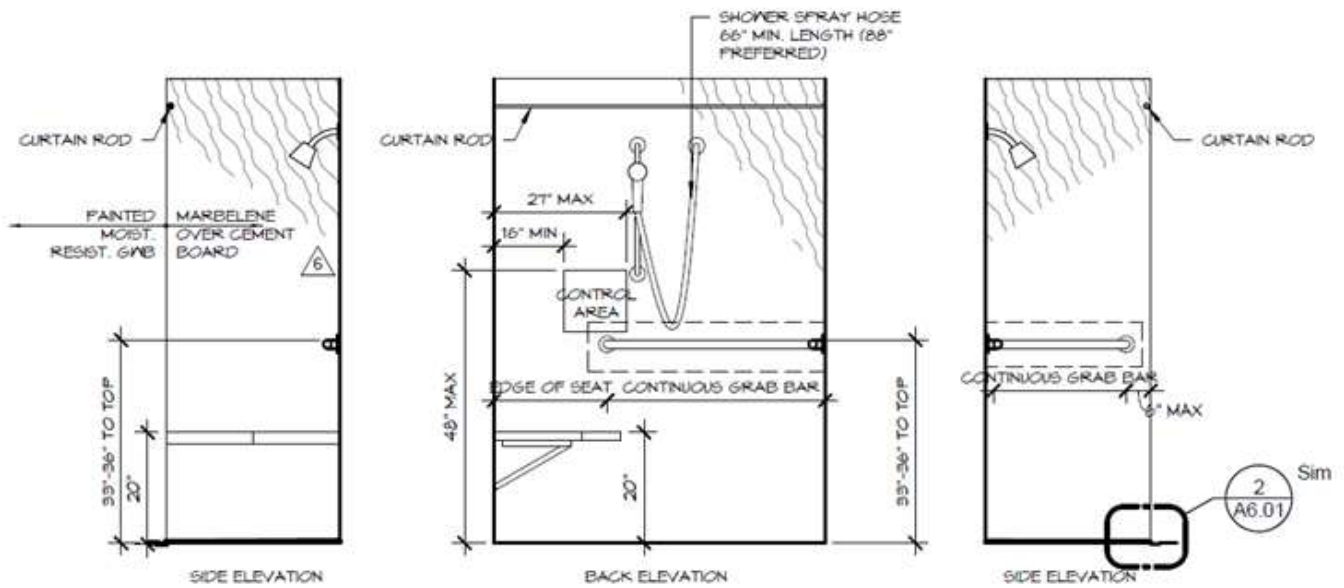
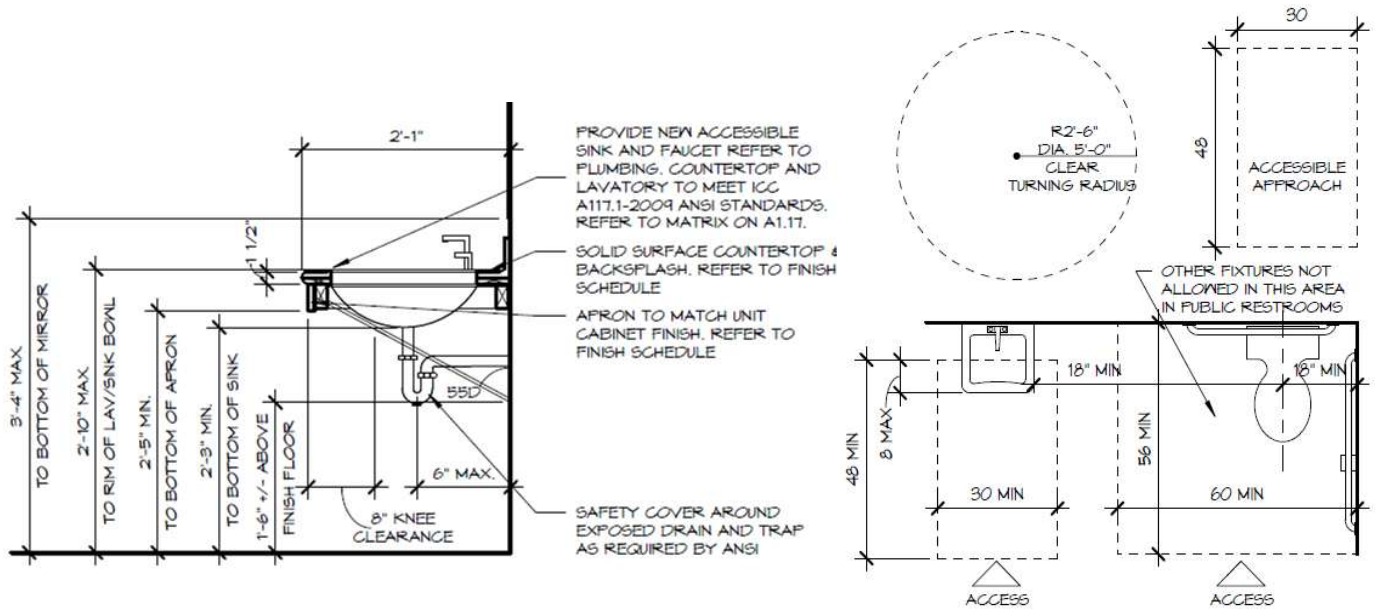

Bathroom Clearances

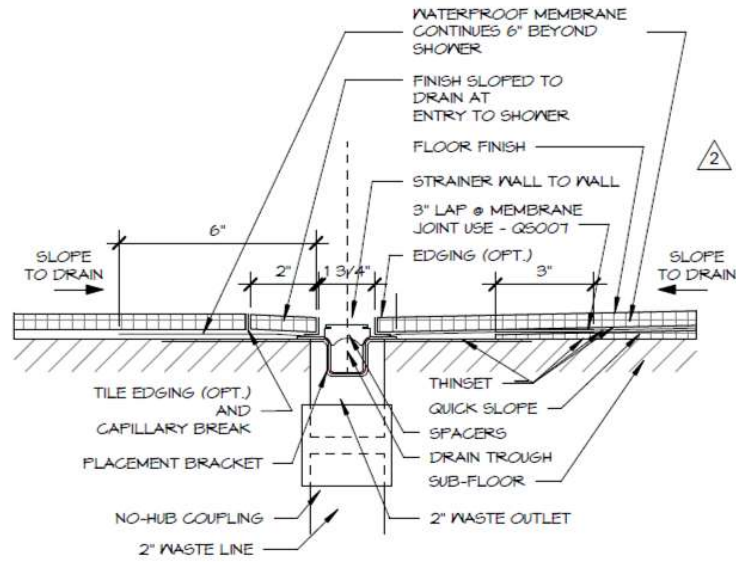

Shower Trench Detail

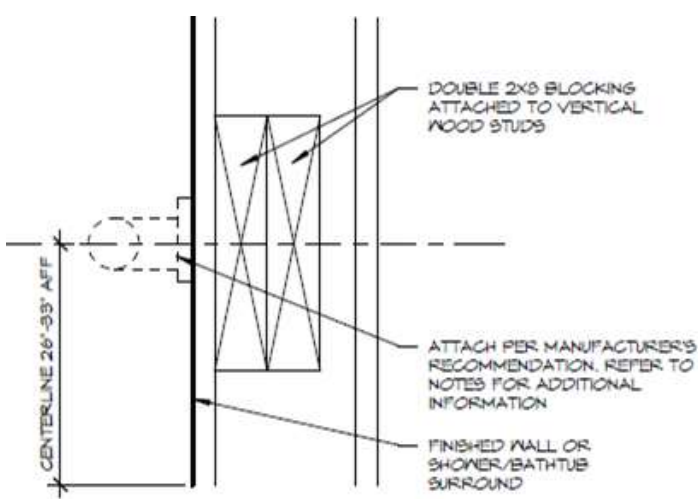

Grab Bar Blocking Detail

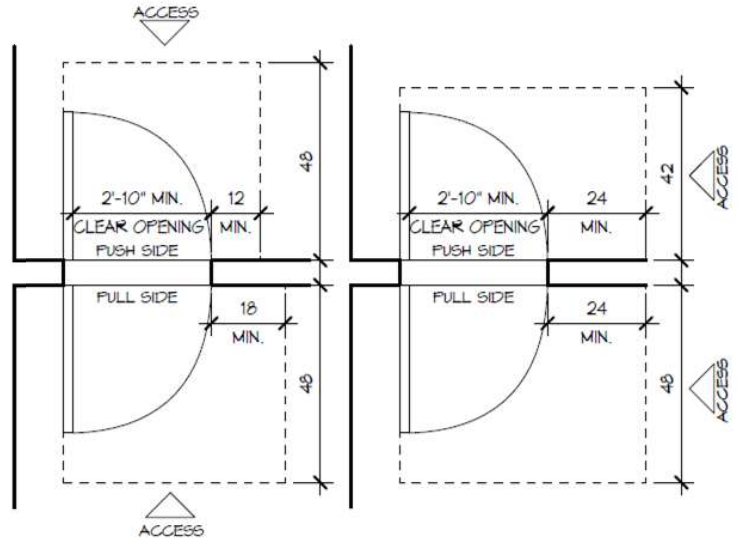

Door Clearances

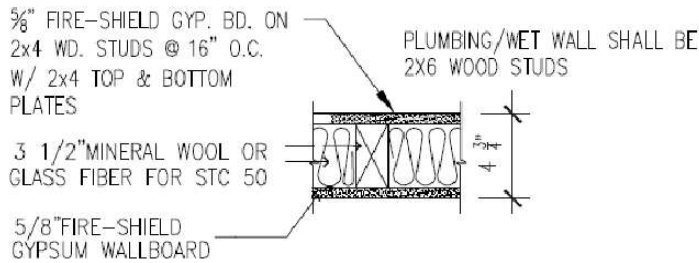

WALL DETAIL 1 @ DEMISING WALLS / UL-U305 GA WP 3605 (1HR) STC35

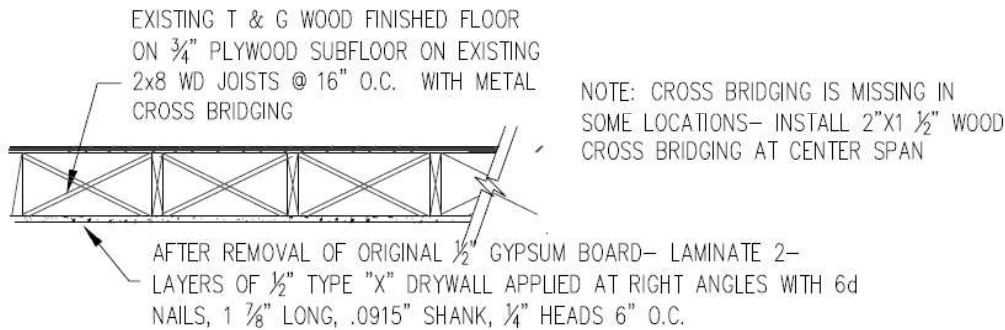

CEILING DETAIL 1

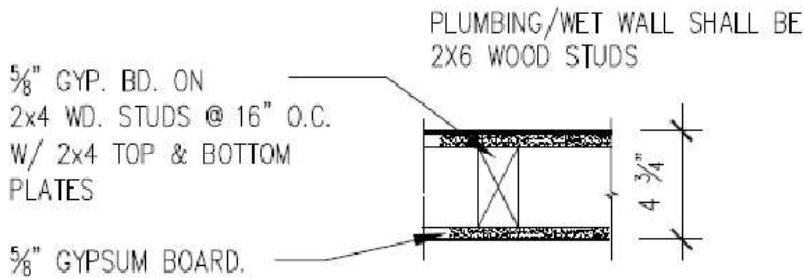

WALL DETAIL 2 @ INTERIOR WALLS

APPLY GYP. BD. EITHER HORIZONTALLY OR VERTICALLY. INNER LAYER ATTACHED TO STUDS W/ 1 7/8" NAILS @ 6" O.C.; OUTER LAYER ATTACHED TO STUDS OVER INNER LAYER W/ 2 3/8" LONG NAILS @ 8" O.C.. VERTICAL JOINTS LOCATED OVER STUDS. STAGGER ALL JOINTS IN FACE LAYER. NAILS 6 D CEMENT COATED NAILS.

NOTE: AT ALL PLUMBING WALLS—USE MOLD TOUGH FIRECORE TYPE "X" GYPSUM BOARD IN THICKNESS AS INDICATED FOR PARTITION

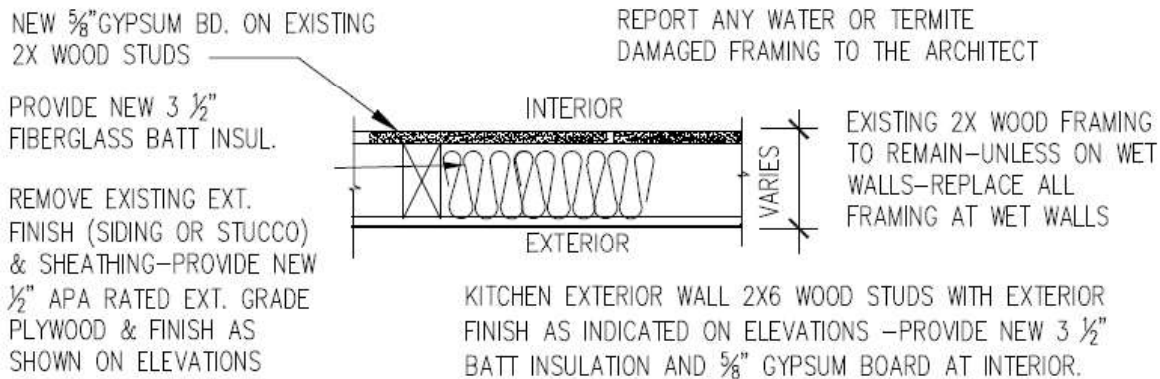

WALL DETAIL 3 @ PERIMETER WALLS

GENERAL SCOPE OF WORK

SOLICITATION # 2026 - 9009

36 Anderson Ferry Apt. #1 - Modernization

36 Anderson Ferry Apt. #1, Cincinnati, OH 45238

Item Category Location Provide product below or as approved equal

Item No.	Category	Location	Provide product below or as approved equal
0	General	Throughout	Refer to <i>Make Ready Procedures</i> for scope and standards for this unit.
26	1st Floor Exterior Entryways	Repair/Re-use Doors	<ul style="list-style-type: none"> *Repair and Paint exterior doors and frame of entry door *Door color: To Match Existing Colors *Clean entry door inside and out *Replace hardware including: hinges, door stop, door closer, and weather seal
34	Interior	Door Hardware	New hardware on all doors. Brushed nickel. Hardware to match existing. Includes Hinges and Door Stops.
36	Interior	Windows	Replace horizontal 1" cordless touver blinds in all window openings. The blinds are to be properly installed per manufacturer specifications. The blinds shall be the proper size (width and length) per window opening. Remove existing blinds and hardware. <i>Color: White</i>
37	Interior	Windows	Ensure all window and tracks are cleaned throughly for proper operation
	Interior	Windows	Re-Screen all windows.
42	Interior	Tile Cleaning	All tile and grout that is not covered with LVT shall be professionally steam cleaned and sealed with MAPEI's UltraCare Grout Sealer.

GENERAL SCOPE OF WORK

43	Interior	Walls, Ceilings, Doors & Trim	<p>Repair all Plaster/Drywall walls and ceiling surfaces including but not limited to: cracks, holes, water damage and bulges. <u>(Must be level 4 Finish before painting)</u></p> <p>Repaint all Walls,(Including Closets) Doors, Bases and Ceiling surfaces. Prime with (1) coat or primer and paint with (2) coats of paint as Specified.</p> <p>Primary wall paint: Promar 200 Interior Latex Eggshell, SW 7015 - Repose Gray (Bathroom to be Semi-gloss)</p> <p>Door paint: Promar 200 Interior Latex Eggshell, SW 7011- Natural Choice (Include Window sills, base trim and door trim)</p> <p>Ceiling paint: Promar 200 Interior Latex Flat. SW 7006 - Extra White</p>
47	Interior	Shelving	<p>Replace all closet shelves with wire shelves. Wire shelves must match existing depth. Bedrooms and front closet must include rod for hanging.</p>
	Interior	Flooring	<p>Remove and dispose of existing flooring in entire unit. Remove any loose or damaged tiles. Apply leveling compound where floor repair was made. Remove all exiting baseboards. Repair drywall as needed.</p> <p>Throughout- Install new LVP using Home Decorators Collection Codron Cove 12 MIL x 12 in. W x 24 in. L Waterproof Click Lock Rigid Core Luxury Vinyl Plank Flooring(19.37 sq.ft./Case) from Home Depot (including all closets).</p> <p>Internet # 332870380 Model # VTRHDCODCV12X24</p> <p>Baseboards and shoe molding- install 4" primed pine and shoe moulding throughout the entire unit.</p> <p>1 in. x 4 in. Radiata Pine Finger Primed Softwood Boards or similar approved.</p> <p>126 1/2 in. x 3/4 in. Primed Finger Jointed Shoe Moulding or similar approved.</p>
14	Interior	Kitchen	<p><u>Replace kitchen cabinets, and countertop.</u> Configuration and dimensions will remain the same.</p> <p>Countertop: Formica White Ice Granite Laminate Brand: Smart Cabinetry- Color: Slate Drawer Glides: Captive Roller (75lbs) Epoxy-coated, full extension Door Hinges: 6-way adjustable self-closing hinges Ultimate Construction: 1/2" Plywood Construction with 2"x6" ACQ pressure treated solid lumber base perimeter touching the floor, laminate interior, and matching exterior. 1/2" plywood sink base floors with 3/4" plywood shelving. Includes plywood drawer bottom. Drawers: Solid Wood Dovetail Drawers</p>

GENERAL SCOPE OF WORK

24	Interior	Kitchen	<p>Replace existing range GE 30 in. 4 Burner Element Free-Standing Electric Range Model # JB256DMWW Color: White</p>
25	Interior	Kitchen	<p>Replace existing Range Hood GE standard Range Hood Model: JV338HWW Color: White</p>
55	Interior	Kitchen	<p>Replace existing Refrigerator GE Energy Star 16.6 Cu. Ft. Top-Freezer Refrigerator Model: GDF535PGRWW Color: White</p>
55	Interior	Kitchen	<p>Replace existing Dishwasher GE Energy Star 24-in Front Control Built-in Dishwasher (White) , Dry Boost , 55-Decibel Model: GTE18DTNRWW Color: White</p>
57	Interior	Bathroom	<p>Install curtain rod and hooks by Moen</p>
61	Interior	Bathroom	<p>Remove and Replace Accessories such as toilet paper holder and towel bar (Finish: Satin Stainless) As well as provide new vanity cabinet above sink. Product: Project Source 15.25-in x 19.25-in Surface Mount White Mirrored Medicine Cabinet</p>
	Interior	Bathroom	<p>Bathtub and surround- Demo existing shower and pan unit. Replace with Aquatic Accessible Smooth Tile AcrylX 1-Piece ADA Shower Stall w/ Right Seat and Grab Bars in White. Faucet- Delta or equal approved Traditional Decorative ADA 9-Spray Patterns 1.75 GPM 3.75 in. Wall Mount Handheld Shower Head in Stainless Model Number: Model # 51900-SS. Contractor to varify all the sizes are correct.</p>
	Interior	Bathroom	<p>Install Plumbing wrap around the piping at the base of the sink to prevent injuries from occuring.</p>
63	Electrical	Throughout	<p>Replace all interior light fixtures with LED fixtures, basement included. * Ceiling surface mounted type: Project Source 1-Light 13-in Nickel LED Flush Mount Light of approved similar * Sconce, 7 in. 1-Light Brushed Nickel Integrated LED Dimmable Half Cylinder Wall Sconce, Selectable CCT * Bathroom - Hampton Bay Woodbury 24.5 in. Brushed Nickel Linear LED Vanity Light Bar, or approved equal</p>

GENERAL SCOPE OF WORK

	Interior	Electrical	<p>Replace all outlet receptacles with new (White) to include covers</p> <p>Replace all switches and covers with new (White)</p> <p>Switches/Receptacles, should be appropriately sized to match breaker amps.</p> <p>Remove any coax cables and receptacles.</p>
64	Electrical	Throughout	<p>Replace Carbon Monoxide/Smoke Detectors:</p> <p>Kidde i4618AC, Firex Smoke/Carbon Mono. Detector, Hardwired with nine-V Battery Backup</p>
	Interior	HVAC	<p>Replace appropriately sized filter.</p> <p>Replace thermostat- Honeywell Home Non-Programmable Thermostat, or approved equal</p> <p>Check the furnace for operability, amps, and terminals.</p> <p>Clean the furnace and all the duct work.</p> <p>Cleaning ductwork with antimicrobial spray involves applying EPA-registered sanitizers (e.g., Bio-Fresh CD, Sporocidin, or Decon 30) via fogging or spraying after cleaning dust and debris to eliminate mold, bacteria, and odors.</p> <p>Initial Cleaning- Before applying any spray, ensure the ductwork is physically cleaned of dust, debris, and mold.</p> <p>Apply Antimicrobial Agent- Use a professional fogger or sprayer to distribute products like Bio-Fresh CD or Benefect Decon 30 into the supply side, allowing the HVAC fan to circulate it.</p> <p>Treatment Area- Treat not just the ducts, but also the evaporator coil, blower motor, and return grate, as these are common areas for mold growth. Replace the intake vent cover on the unit.</p> <p>Remove and replace pipe insulation in mechanical closet with ½ Polyethylene Semi-Slit</p> <p><i>Secure insulation with tane intended for use with polyethylene.</i></p>
72	HVAC	Vents	<p>Replace all vent covers. White</p>
	Plumbing	ADA Toilet	<p>HOROW</p> <p>17 in. ADA 2-Piece 1.28 GPF Single Flush Elongated Toilet in White</p> <p>Map Flush 1000g, Soft-Close Seat Included</p>
79	Interior	Cleaning & Make Ready	<p>Professionally clean entire house for management turn over. Ensure all items not covered in this Schedule of Work is completed in accordance with the attached Make Ready standards and specifications.</p>
80	General	Contractor Note	<p>Contractor responsible for obtaining any necessary permits and submitting copies to CMHA.</p>

"General Decision Number: OH20260010 01/02/2026

Superseded General Decision Number: OH20250010

State: Ohio

Construction Type: Residential

County: Hamilton County in Ohio.

RESIDENTIAL CONSTRUCTION PROJECTS (consisting of single family homes and apartments up to and including 4 stories).

Modification Number 0 Publication Date 01/02/2026

BROH0018-007 06/01/2024

	Rates	Fringes
BRICKLAYER.....	\$ 35.00	17.13

ELEC0212-004 06/02/2025

	Rates	Fringes
ELECTRICIAN.....	\$ 38.05	22.97

ENGI0018-027 05/01/2019

	Rates	Fringes
POWER EQUIPMENT OPERATOR (Bulldozer).....	\$ 37.02	15.20

ENGI0066-026 06/01/2023

	Rates	Fringes
POWER EQUIPMENT OPERATOR Crane.....	\$ 36.92	24.01

LAB00265-004 06/01/2024

	Rates	Fringes
LABORER (Mason Tender-Brick).....	\$ 25.90	18.40

PAIN0707-001 05/01/2025

	Rates	Fringes
PAINTER (Brush and Roller).....	\$ 33.95	20.20

PLAS0109-006 06/01/2025

	Rates	Fringes
CEMENT MASON/CONCRETE FINISHER...\$	33.48	24.81

SFOH0669-007 06/01/2025

Rates Fringes

SPRINKLER FITTER (Fire Sprinklers).....	\$ 48.28	28.08
---	----------	-------

SHEE0033-016 06/01/2025

	Rates	Fringes
--	-------	---------

SHEET METAL WORKER (HVAC Duct Installation Only).....	\$ 20.40	16.50
---	----------	-------

SUOH2012-009 07/20/2012

	Rates	Fringes
--	-------	---------

CARPENTER.....	\$ 27.29	0.00
LABORER: Common or General.....	\$ 23.40	0.00
OPERATOR: Backhoe/Excavator.....	\$ 25.25	9.38
OPERATOR: Bobcat/Skid Steer/Skid Loader.....	\$ 29.49	11.16
PLUMBER.....	\$ 20.00	5.52
ROOFER.....	\$ 19.22	0.00

WELDERS - Receive rate prescribed for craft performing operation to which welding is incidental.

=====
Note: Executive Order (EO) 13706, Establishing Paid Sick Leave for Federal Contractors applies to all contracts subject to the Davis-Bacon Act for which the contract is awarded (and any solicitation was issued) on or after January 1, 2017. If this contract is covered by the EO, the contractor must provide employees with 1 hour of paid sick leave for every 30 hours they work, up to 56 hours of paid sick leave each year. Employees must be permitted to use paid sick leave for their own illness, injury or other health-related needs, including preventive care; to assist a family member (or person who is like family to the employee) who is ill, injured, or has other health-related needs, including preventive care; or for reasons resulting from, or to assist a family member (or person who is like family to the employee) who is a victim of, domestic violence, sexual assault, or stalking. Additional information on contractor requirements and worker protections under the EO is available at <https://www.dol.gov/agencies/whd/government-contracts>.

Note: Executive Order 13658 generally applies to contracts subject to the Davis-Bacon Act that were awarded on or between January 1, 2015 and January 29, 2022, and that have not been renewed or extended on or after January 30, 2022. Executive Order 13658 does not apply to contracts subject only to the Davis-Bacon Related Acts regardless of when they were awarded. If a contract is subject to Executive Order 13658, the contractor must pay all covered workers at least \$13.30 per hour (or the applicable wage rate listed on this wage determination, if it is higher) for all hours spent performing on the contract in 2025. The applicable Executive Order minimum wage rate will be adjusted annually. Additional

information on contractor requirements and worker protections under Executive Order 13658 is available at www.dol.gov/whd/govcontracts.

Unlisted classifications needed for work not included within the scope of the classifications listed may be added after award only as provided in the labor standards contract clauses (29CFR 5.5 (a) (1) (iii)).

The body of each wage determination lists the classifications and wage rates that have been found to be prevailing for the type(s) of construction and geographic area covered by the wage determination. The classifications are listed in alphabetical order under rate identifiers indicating whether the particular rate is a union rate (current union negotiated rate), a survey rate, a weighted union average rate, a state adopted rate, or a supplemental classification rate.

Union Rate Identifiers

A four-letter identifier beginning with characters other than ""SU"", ""UAVG"", ?SA?, or ?SC? denotes that a union rate was prevailing for that classification in the survey. Example: PLUM0198-005 07/01/2024. PLUM is an identifier of the union whose collectively bargained rate prevailed in the survey for this classification, which in this example would be Plumbers. 0198 indicates the local union number or district council number where applicable, i.e., Plumbers Local 0198. The next number, 005 in the example, is an internal number used in processing the wage determination. The date, 07/01/2024 in the example, is the effective date of the most current negotiated rate.

Union prevailing wage rates are updated to reflect all changes over time that are reported to WHD in the rates in the collective bargaining agreement (CBA) governing the classification.

Union Average Rate Identifiers

The UAVG identifier indicates that no single rate prevailed for those classifications, but that 100% of the data reported for the classifications reflected union rates. EXAMPLE: UAVG-OH-0010 01/01/2024. UAVG indicates that the rate is a weighted union average rate. OH indicates the State of Ohio. The next number, 0010 in the example, is an internal number used in producing the wage determination. The date, 01/01/2024 in the example, indicates the date the wage determination was updated to reflect the most current union average rate.

A UAVG rate will be updated once a year, usually in January, to reflect a weighted average of the current rates in the collective bargaining agreements on which the rate is based.

Survey Rate Identifiers

The ""SU"" identifier indicates that either a single non-union rate prevailed (as defined in 29 CFR 1.2) for this classification in the survey or that the rate was derived by computing a weighted average rate based on all the rates reported in the survey for that classification. As a weighted average rate includes all rates reported in the survey, it may

include both union and non-union rates. Example: SUFL2022-007 6/27/2024. SU indicates the rate is a single non-union prevailing rate or a weighted average of survey data for that classification. FL indicates the State of Florida. 2022 is the year of the survey on which these classifications and rates are based. The next number, 007 in the example, is an internal number used in producing the wage determination. The date, 6/27/2024 in the example, indicates the survey completion date for the classifications and rates under that identifier.

?SU? wage rates typically remain in effect until a new survey is conducted. However, the Wage and Hour Division (WHD) has the discretion to update such rates under 29 CFR 1.6(c)(1).

State Adopted Rate Identifiers

The ""SA"" identifier indicates that the classifications and prevailing wage rates set by a state (or local) government were adopted under 29 C.F.R 1.3(g)-(h). Example: SAME2023-007 01/03/2024. SA reflects that the rates are state adopted. ME refers to the State of Maine. 2023 is the year during which the state completed the survey on which the listed classifications and rates are based. The next number, 007 in the example, is an internal number used in producing the wage determination. The date, 01/03/2024 in the example, reflects the date on which the classifications and rates under the ?SA? identifier took effect under state law in the state from which the rates were adopted.

WAGE DETERMINATION APPEALS PROCESS

1) Has there been an initial decision in the matter? This can be:

- a) a survey underlying a wage determination
- b) an existing published wage determination
- c) an initial WHD letter setting forth a position on a wage determination matter
- d) an initial conformance (additional classification and rate) determination

On survey related matters, initial contact, including requests for summaries of surveys, should be directed to the WHD Branch of Wage Surveys. Requests can be submitted via email to davisbaconinfo@dol.gov or by mail to:

Branch of Wage Surveys
Wage and Hour Division
U.S. Department of Labor
200 Constitution Avenue, N.W.
Washington, DC 20210

Regarding any other wage determination matter such as conformance decisions, requests for initial decisions should be directed to the WHD Branch of Construction Wage Determinations. Requests can be submitted via email to BCWD-Office@dol.gov or by mail to:

Branch of Construction Wage Determinations
Wage and Hour Division
U.S. Department of Labor
200 Constitution Avenue, N.W.
Washington, DC 20210

2) If an initial decision has been issued, then any interested party (those affected by the action) that disagrees with the decision can request review and reconsideration from the Wage and Hour Administrator (See 29 CFR Part 1.8 and 29 CFR Part 7). Requests for review and reconsideration can be submitted via email to dba.reconsideration@dol.gov or by mail to:

Wage and Hour Administrator
U.S. Department of Labor
200 Constitution Avenue, N.W.
Washington, DC 20210

The request should be accompanied by a full statement of the interested party's position and any information (wage payment data, project description, area practice material, etc.) that the requestor considers relevant to the issue.

3) If the decision of the Administrator is not favorable, an interested party may appeal directly to the Administrative Review Board (formerly the Wage Appeals Board). Write to:

Administrative Review Board
U.S. Department of Labor
200 Constitution Avenue, N.W.
Washington, DC 20210.

=====

END OF GENERAL DECISION

"